A Portamatrices guiados por columnas

de fundición, acero y aluminio
Portamatrices, pequeñas prensas a columnas, útiles, portamatrices de cambio rápido

B Placas y regletas rectificadas

C Elementos de transporte y sujeción

D Elementos de guía

E Elementos de precisión

F Muelles/resortes

G Elastómeros

H Productos químicos FIBRO

J Periféricos

K Carros para troqueles

L Elementos normalizados para la construcción de moldes



Portamatrices de columnas, de fundición, acero y aluminio

Ejecución

Los contornos de las placas en ejecución standard son cortadas por oxicorte, rebardadas y barnizadas. Sobre pedido, las partes frontales pueden ser mecanizadas (prevenir la tolerancia en menos). El grosor de las placas tiene una tolerancia de ± 2 mm. Sobre pedido pueden suministrarse también tolerancias más estrechas.

Elementos de guía

Los portamatrices, en ejecución standard, van guiados por columnas DIN 9825/ISO 9182 (202.19.) y casquillos con valona DIN 9831/ISO 9448 (2081.).

Para datos técnicos consulten por favor el capítulo «Elementos de guía».

Elementos para manipulación y transporte

En unas placas de medidas $a_1+b_1 \geq 1000$ mm un peso de placa de ≥ 100 kg están previstos 2 agujeros roscados por cada placa. Sobre pedido se suministran los cáncamos correspondientes.

Portamatrices especiales y placas de acero y aluminio según plano del cliente

Hasta 2200×1100 mm de medidas exteriores fabricamos placas y portamatrices según planos del cliente con la máxima precisión.

Mecanizados especiales

Las oberturas, fresadas y mandrinadas en desbaste, deberían ser hechas por FIBRO siempre que sea posible. ya que operaciones posteriores de gran desbaste, como sabemos por experiencia, frecuentemente producen deformaciones.

Formularios de consulta y pedido para portamatrices especiales (véase también paginas A30 – A33)

Para las dimensiones de ejecuciones especiales, tenemos a su disposición cuestionarios y formularios de pedido. Será suficiente acotar y marcar el sistema de guía elegido sobre dichos formularios.

Indice

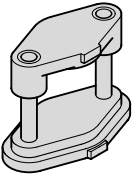
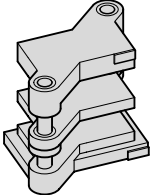
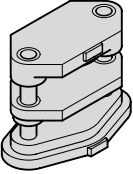
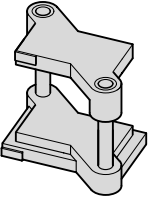
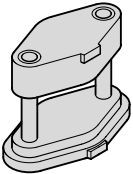
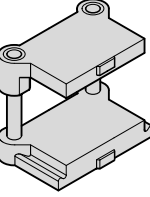
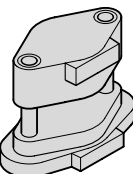
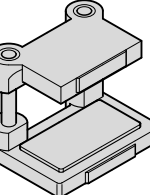
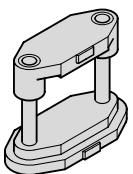
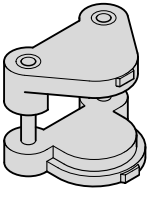
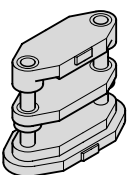
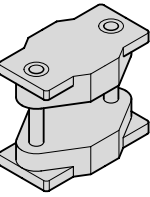
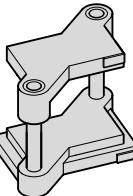
		Página		Página
Descripción de guías lisas, a bolas y a rodillos		A7		
Portamatrices de fundición		A9–A22		
	201.01.	A10		201.23. A17
	201.03.	A11		201.26. A18
	201.05.	A12		201.31. A19
	201.07.	A13		201.33. A20
	201.11.	A14		201.36. A21
	201.13.	A15		201.39. A22
	201.21.	A16		

Portamatrices de acero y aluminio guiados por columnas

A23–A41

Portamatrices standard con placas de acero
(sin placa intermedia)

A24–A28

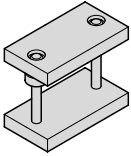

2010.45.

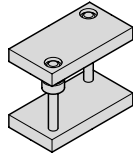

2010.46.

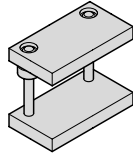

2010.47.

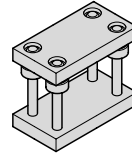

2010.49.

Portamatrices standard con placas de acero
(con placa intermedia)

A25–A29

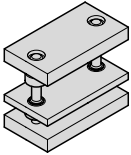

2010.45.

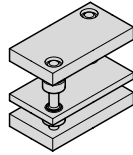

2010.46.

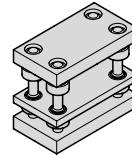

2010.49.

Formularios de pedido – Dimensiones y ejecuciones
especiales (con o sin placa intermedia)

A30–A33

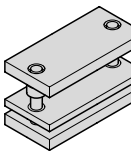

201.45.
201.65.

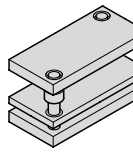

201.46.
201.66.

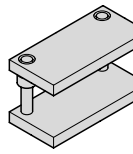

201.47.
201.67.

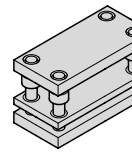

201.49.
201.69.

Placas en acero y en aleación de aluminio

A34–A35

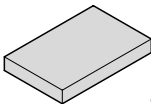

2900.
2910.

Portamatrices standard con placas de aleación de
aluminio (sin placa intermedia)

A36–A40

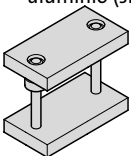

2010.65.

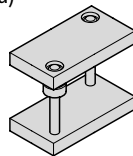

2010.66.

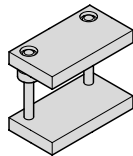

2010.67.

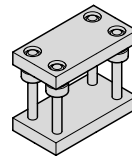

2010.69.

Portamatrices standard con placas de aleación de
aluminio (con placa intermedia)

A37–A41

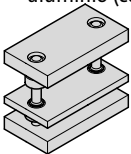

2010.65.

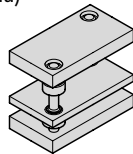

2010.66.

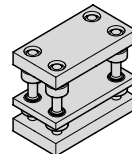

2010.69.

Indice

Página

Portamatrices/Pequeñas prensas a columnas

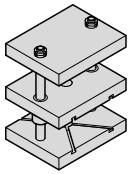

2011.45.

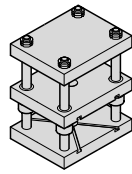

2011.49

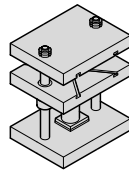

201.145.

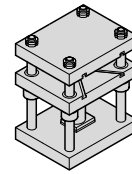

201.149.

A42–A44

Portamatrices especiales con placas de acero
(según especificación del cliente)

A45–A48

Portamatrices para matrices progresivas

A49–A55

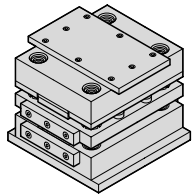

201.50.

Portamatrices de cambio rápido

A57–A63

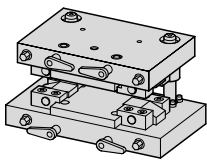

201.95.

FIBRO

Descripción de guías lisas, a bolas y a rodillos

FIBRO material sinterizado empleado en la construcción de guías de precisión lisas

Se trata de hierro sinterizado de gran pureza con superficie carbonitrurada.

Las superficies de contacto con la columna son finamente rectificadas y lapeadas. Los poros del material sinterizado representan un 18 al 20 % del volumen total, y son impregnados en vacío con aceite especial FIBROLIT-LD. Como complemento de lubricación de larga duración se recomienda que las ranuras interiores del casquillo de guía se llenen con grasa FIBROLIT-Fett LD 280.34. Para más información, véase página H 14.

Aceites con disulfuro de molibdeno no pueden ser empleados en lubricaciones posteriores.

Clasificación de tolerancias: ver página D 11.

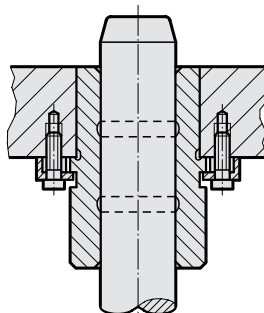

Guía lisa de precisión FIBRO con recubrimiento de bronce

consistente en un cuerpo base de acero con superficies de contacto recubiertas de bronce, con ranura de engrase en espiral y engrasador para el engrase posterior.

El cuerpo de acero garantiza una excelente resistencia a la rotura, incluso bajo fuertes cargas laterales.

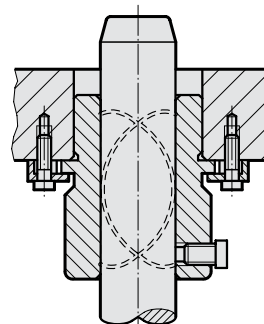

Guías de precisión a bolas FIBRO

Una construcción extremadamente cuidadosa y de precisión. Bolas de tolerancias muy estrechas y una pre-carga correcta* aseguran un funcionamiento prácticamente sin juego. De las ventajas de la fricción rodante se obtiene un resultado óptimo cuando las superficies de rodadura son de un rectificado en acabado muy fino y lapeadas. Gracias a la suavidad de deslizamiento lineal de este sistema, el mismo es empleado preferentemente por los constructores de útiles. Las guías a bolas FIBRO se equipan en su ejecución standard con jaulas de bolas de latón, las cuales, por su gran cantidad de bolas y robustez, dan los mejores resultados de rendimiento. En cierta manera, todo elemento guiado por bolas tiene la tendencia a ser algo inestable (contacto mínimo de las bolas), y solamente un sobredimensionado de las guías puede corregir este inconveniente.

* Pre-carga media según diámetro:

de \varnothing 8 hasta \varnothing 12 = 4 μ m
 de \varnothing 15 hasta \varnothing 16 = 7–9 μ m
 de \varnothing 18 hasta \varnothing 42 = 9–11 μ m
 de \varnothing 50 hasta \varnothing 80 = 11–13 μ m

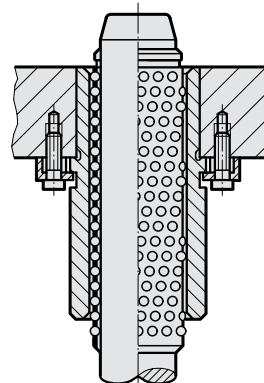

Guías de precisión a rodillos FIBRO

La carga que admite una guía a rodillos es específicamente superior a la de una guía a bolas. Gracias a la mayor superficie de contacto de los rodillos en comparación con la de bolas, las condiciones de pretensión pueden ser marcadamente inferiores.

La pre-carga media, según el diámetro, es:

Para carga estática o movimiento lento

hasta \varnothing 25 = 2,5 μ m
 \varnothing 30/32 = 3 μ m
 \varnothing 40–50 = 3,5 μ m
 \varnothing 63 = 4 μ m

Para carga dinámica o movimiento rápido

hasta \varnothing 25 = 1,5 μ m
 \varnothing 30/32 = 2 μ m
 \varnothing 40–50 = 2,5 μ m
 \varnothing 63 = 3 μ m

Emplear solamente clase de emparejamiento:
 columna de guía rojo = .30
 casquillo de guía amarillo = .10

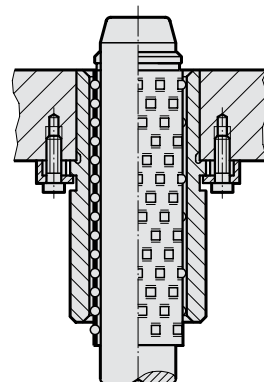

Portamatrices de fundición

Portamatrices de fundición
DIN 9812 formas D y DG

201.01.



201.01.

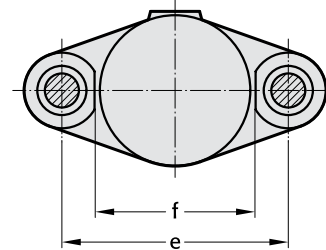

Sección A - A

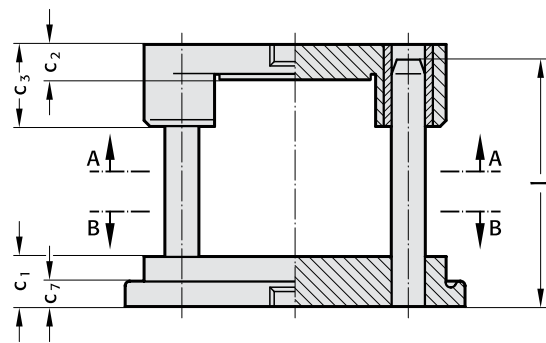

Sección B - B

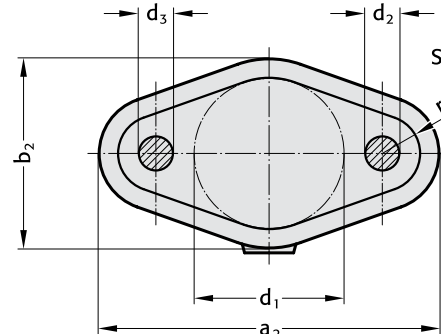

Modo de guiado

Guía con casquillo metal sinterizado carbonitrurado

Guía a bolas

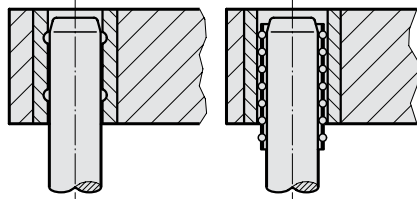

Código, parte II

A elegir con o sin taladro roscado para tirante en la parte superior

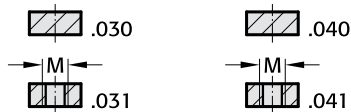

201.01.

Código parte I	Superf. trabajo													
	d ₁	a ₂	b ₂	c ₁	c ₂	c ₃	c ₇	d ₂	d ₃	e	f	l	r	M
201.01.063	63	182	100	40	25	60	20	16	15	106	73	140	20	16x1,5
080	80	236	120	50	30	80	30	20	19	140	90	160	28	20x1,5
100	100	275	140	50	30	80	30	25	24	165	110	160	35	20x1,5
125	125	300	165	50	30	80	30	25	24	190	139	160	35	20x1,5
160	160	360	200	56	40	90	30	32	30	240	174	180	40	24x1,5
180	180	380	220	56	40	90	30	32	30	260	194	180	40	24x1,5
200	200	400	240	56	40	90	30	32	30	280	218	180	40	24x1,5
250	250	496	300	56	50	100	30	40	38	350	268	200	48	30x2
315	315	563	365	63	50	100	30	40	38	417	333	224	48	30x2

Ejemplo de pedido:

Portamatrices = 201.01.
 Superf. trabajo 160 mm = 160.
 Casq. guía sinteriz. sin taladro roscado para tirante = 030
 Código = 201.01.160.030

FIBRO

201.03.

Portamatrices de fundición
DIN 9814 formas D y DG

201.03.

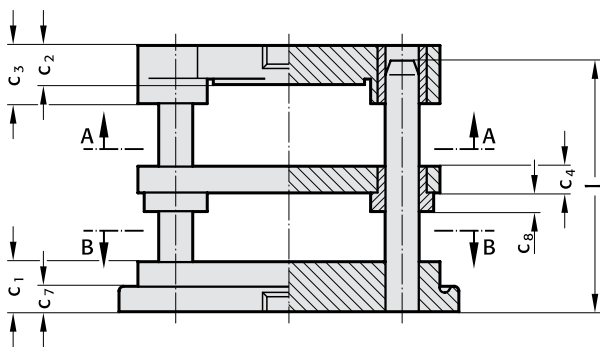
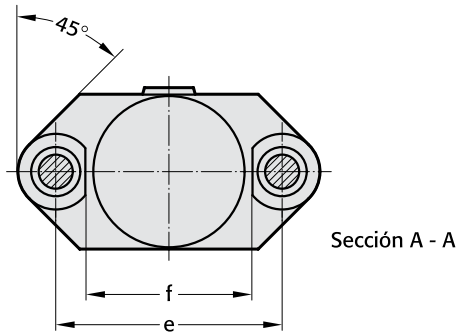

Modo de guiado

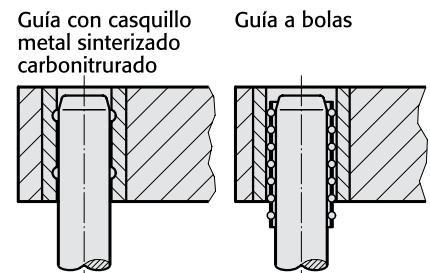

A elegir con placa intermedia

acero

acero

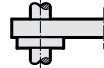
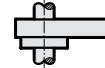

Código, parte II
A elegir con o sin taladro roscado para tirante en la parte superior

.034

.054

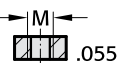
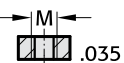

201.03.

Código parte I	Superf. trabajo															
	d ₁	a ₂	b ₂	c ₁	c ₂	c ₃	c ₄	c ₇	c ₈	d ₂	d ₃	e	f	l	r	M
201.03.100	100	275	140	50	30	50	22	30	18	25	24	165	119	160	35	20x1,5
125	125	300	165	50	30	50	22	30	18	25	24	190	144	160	35	20x1,5
160	160	360	200	56	40	60	27	30	18	32	30	240	184	180	40	24x1,5

Ejemplo de pedido:

Portamatrices = 201.03.
 Superf. trabajo 125 mm = 125.
 Casq. guía sinteriz. con placa intermedia y sin taladro roscado para tirante = 034
 Código = 201.03.125.034

Portamatrices de fundición,
DIN 9816 forma D

201.05.



201.05.

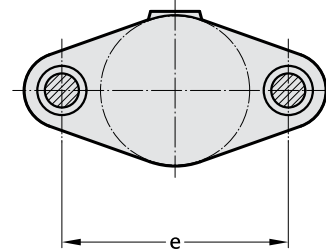

Sección A - A

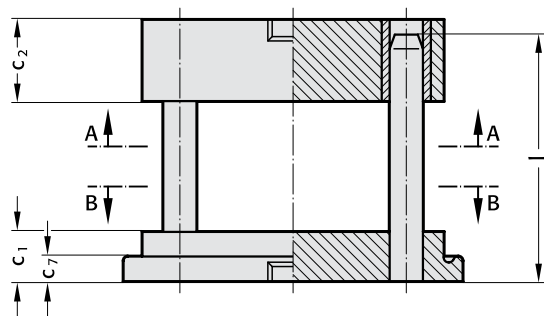

Sección B - B

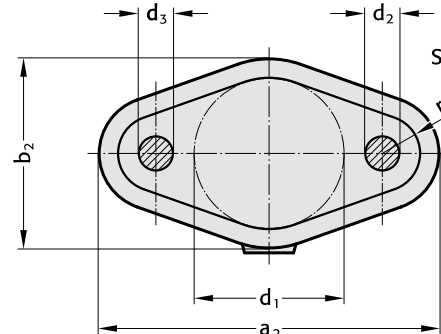

Modo de guiado

Guía con casquillo
metal sinterizado
carbonitrurado

Guía a bolas

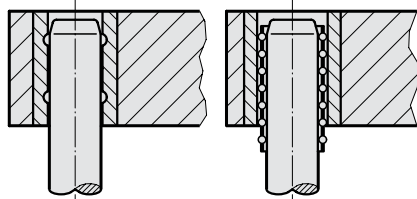

Código, parte II
sin taladro roscado para tirante en la parte superior



201.05.

Código parte I	Superf. trabajo										
	d ₁	a ₂	b ₂	c ₁	c ₂	c ₇	d ₂	d ₃	e	l	r
201.05.063	63	182	100	40	65	20	16	15	106	140	20
080	80	236	120	50	70	30	20	19	140	160	28
100	100	275	140	50	75	30	25	24	165	180	35
125	125	300	165	50	80	30	25	24	190	180	35
160	160	360	200	56	90	30	32	30	240	224	40
200	200	400	240	56	100	30	32	30	280	224	40

Ejemplo de pedido:

Portamatrices = 201.05.
 Sup. trabajo 100 mm = 100.
 Casq. guía sinter. carbonit. = 030
 Código = 201.05.100.030

FIBRO

201.07.

Portamatrices de fundición similar a DIN 9816 forma D

201.07.

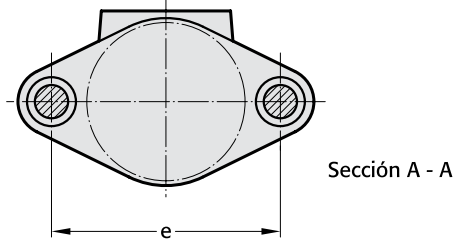

Sección A - A

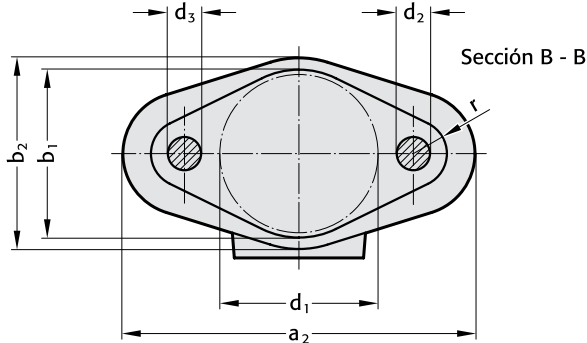
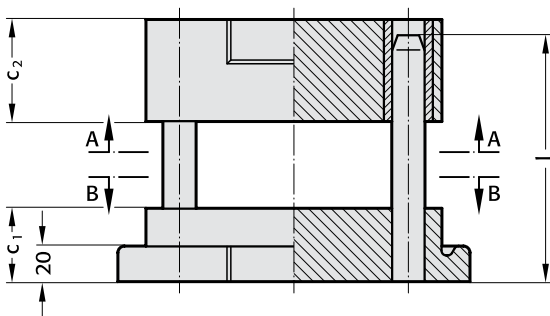

Sección B - B



Modo de guiado

Guía con casquillo metal sinterizado carbonitrurado

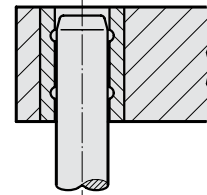

Código, parte II
sin taladro roscado para tirante en placa superior



201.07.

Código parte I	Superf. trabajo										
		d ₁	a ₂	b ₁	b ₂	c ₁	c ₂	d ₂	d ₃	e	l
201.07.040.030	40	112	45	55	36	40	16	15	66	100	13
063.030	63	142	68	78	40	55	16	15	90	125	14

Ejemplo de pedido:

Portamatrices	=	201.07.
Superf. trabajo 40 mm	=	040.
Casq. guía sinter. carbonit.	=	030
Código	=	201.07.040.030

Portamatrices de fundición
DIN 9812 formas C y CG

201.11.



201.11.

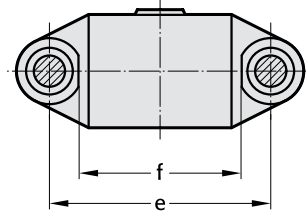

Sección A - A

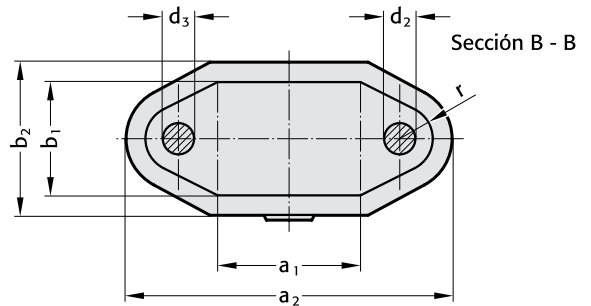
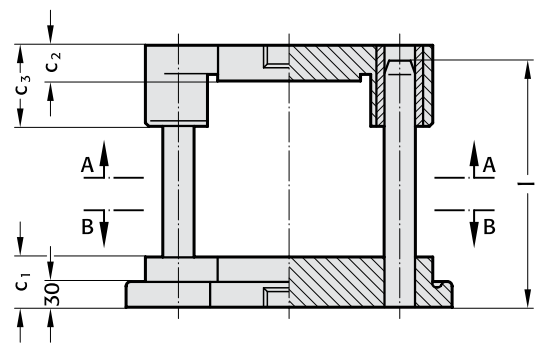

Sección B - B

Modo de guiado

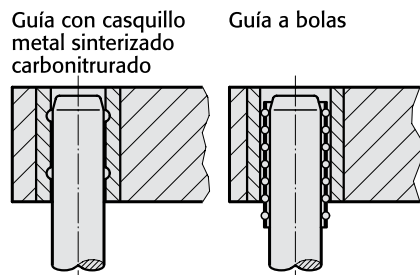

Código, parte II
A elegir con o sin taladro roscado para tirante en parte superior

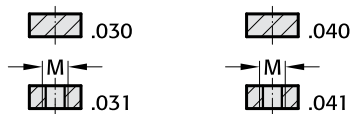

201.11.

Código parte I	Superf. trabajo												
	a ₁ x b ₁	a ₂	b ₂	c ₁	c ₂	c ₃	d ₂	d ₃	e	f	l	r	M
201.11.070.050	70 x 50	170	70	40	22	50	20	19	110	73	140	20	20x1,5
080.063	80 x 63	235	103	50	30	80	20	19	140	90	160	27	20x1,5
100.063	100 x 63	253	103	50	30	80	20	19	158	110	160	27	20x1,5
080	100 x 80	265	120	50	30	80	25	24	165	110	160	30	20x1,5
201.11.125.080	125 x 80	290	120	50	30	80	25	24	190	139	160	30	20x1,5
160.080	160 x 80	325	120	50	30	80	25	24	225	174	160	30	20x1,5
200.080	200 x 80	365	120	50	30	80	25	24	265	218	160	30	20x1,5
125.100	125 x 100	290	140	50	40	90	25	24	190	139	160	30	24x1,5
160.100	160 x 100	325	140	50	40	90	25	24	225	174	160	30	24x1,5
200.100	200 x 100	395	140	56	40	90	32	30	280	218	180	37	24x1,5
160.125	160 x 125	355	165	56	40	90	32	30	240	174	180	37	24x1,5
200.125	200 x 125	395	165	56	40	90	32	30	280	218	180	37	24x1,5
250.125	250 x 125	445	165	56	40	90	32	30	330	268	180	37	24x1,5
315.125	315 x 125	510	165	56	40	90	32	30	395	333	180	37	24x1,5
200.160	200 x 160	395	200	56	50	100	32	30	280	218	200	37	30x2
250.160	250 x 160	445	200	56	50	100	32	30	330	268	200	37	30x2
200	250 x 200	496	250	63	50	100	40	38	350	268	224	48	30x2
201.11.315.200	315 x 200	563	250	63	50	100	40	38	417	333	224	48	30x2
250	315 x 250	563	300	63	50	100	40	38	417	333	224	48	30x2

FIBRO

201.13.

Portamatrices de fundición DIN 9814 formas C y CG

201.13.

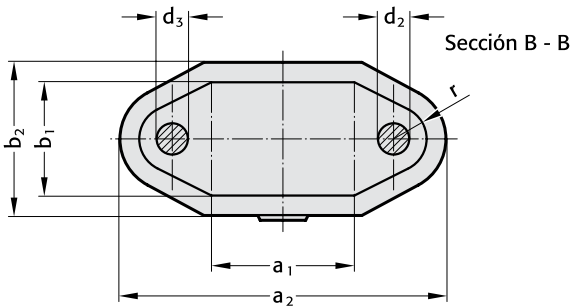
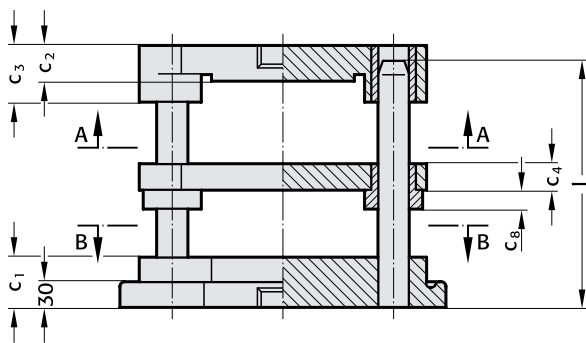
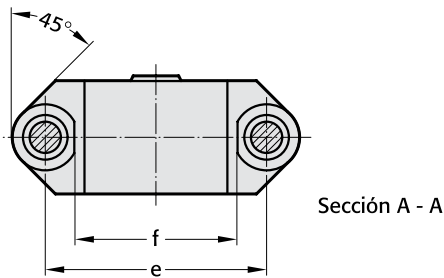

Modo de guiado

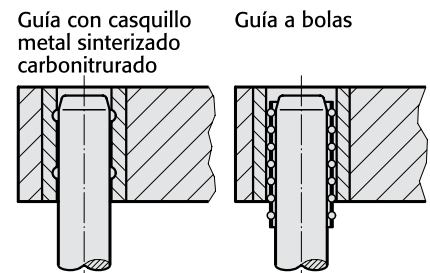

A elegir con placa intermedia

acero

acero

Código, parte II
A elegir con o sin taladro roscado para tirante en placa superior

.034

.054

M
.035

M
.055

201.13.

Código parte I	Superf. trabajo a ₁ x b ₁	a ₂	b ₂	c ₁	c ₂	c ₃	c ₄	c ₈	d ₂	d ₃	e	f	l	r	M
201.13.080.063	80 x 63	235	103	50	30	50	18	14	20	19	140	104	160	27	20x1,5
100.080	100 x 80	265	120	50	30	50	22	18	25	24	165	119	160	30	20x1,5
125.100	125 x 100	290	140	50	40	60	22	18	25	24	190	144	160	30	24x1,5
160.125	160 x 125	355	165	56	40	60	27	18	32	30	240	184	180	37	24x1,5
200.160	200 x 160	395	200	56	50	70	27	18	32	30	280	224	200	37	30x2

Ejemplo de pedido:

Portamatrices	= 201.13.
Superf. trabajo 125 x 100 mm	= 125.100.
Casq. guía sinterizado con placa intermedia de acero, sin taladro roscado para tirante	= 034
Código	= 201.13.125.100.034

Portamatrices de fundición
DIN 9819 formas C y CG

201.21.



201.21.

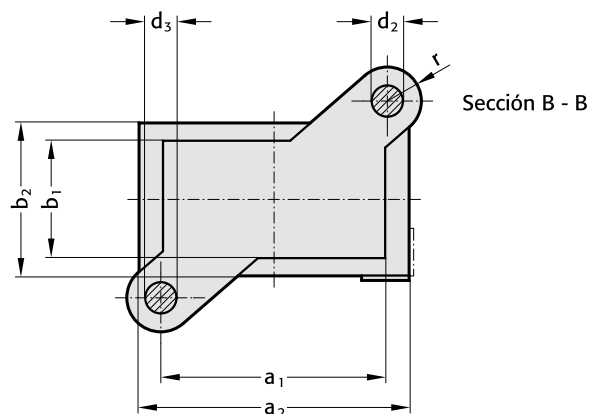
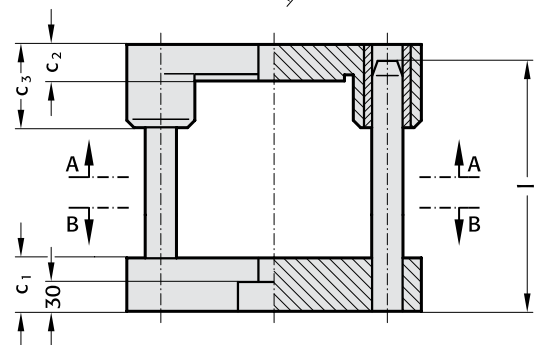
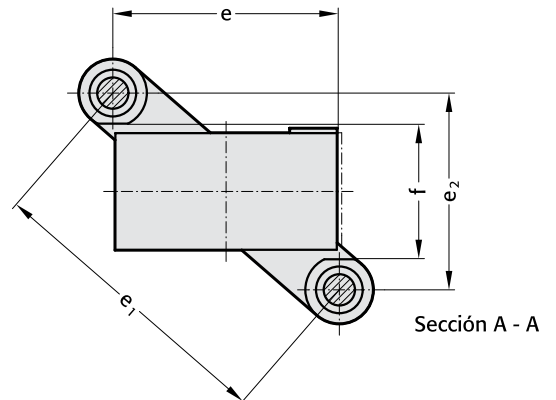

Modo de guiado

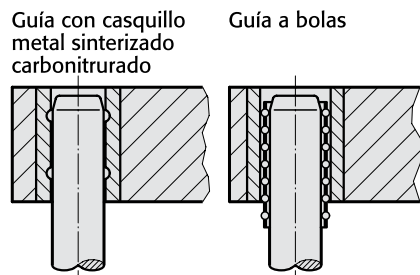

Código, parte II
A elegir con o sin taladro roscado para tirante en parte superior

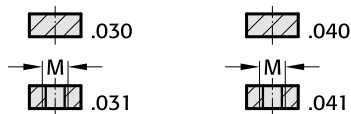

201.21.

Código parte I	Superf. trabajo															
	a ₁ x b ₁	a ₂	b ₂	c ₁	c ₂	c ₃	d ₂	d ₃	e	e ₁	e ₂	f	l	r	M	
201.21.080.063	80 x 63	120	103	50	30	80	20	19	80	145	121	73	160	27	20x1,5	
100.063	100 x 63	140	103	50	30	80	20	19	100	157	121	73	160	27	20x1,5	
080	100 x 80	140	120	50	30	80	25	24	100	175	144	90	160	30	20x1,5	
201.21.125.080	125 x 80	165	120	50	30	80	25	24	125	191	144	90	160	30	20x1,5	
100	125 x 100	165	140	50	40	90	25	24	125	206	164	110	160	30	24x1,5	
201.21.160.100	160 x 100	200	140	50	40	90	25	24	160	229	164	110	160	30	24x1,5	
200.100	200 x 100	240	140	56	40	90	32	30	200	268	179	110	180	37	24x1,5	
160.125	160 x 125	200	165	56	40	90	32	30	160	259	204	139	180	37	24x1,5	
200.125	200 x 125	240	165	56	40	90	32	30	200	286	204	139	180	37	24x1,5	
250.125	250 x 125	290	165	56	40	90	32	30	250	323	204	139	180	37	24x1,5	
315.125	315 x 125	355	165	56	40	90	32	30	315	375	204	139	180	37	24x1,5	
200.160	200 x 160	240	200	56	50	100	32	30	200	312	240	174	200	37	30x2	
250.160	250 x 160	290	200	56	50	100	32	30	250	346	240	174	200	37	30x2	
200	250 x 200	300	250	63	50	100	40	38	250	392	302	218	224	48	30x2	
201.21.315.200	315 x 200	365	250	63	50	100	40	38	315	436	302	218	224	48	30x2	
250	315 x 250	365	300	63	50	100	40	38	315	472	352	268	224	48	30x2	

FIBRO

201.23.

Portamatrices de fundición

201.23.

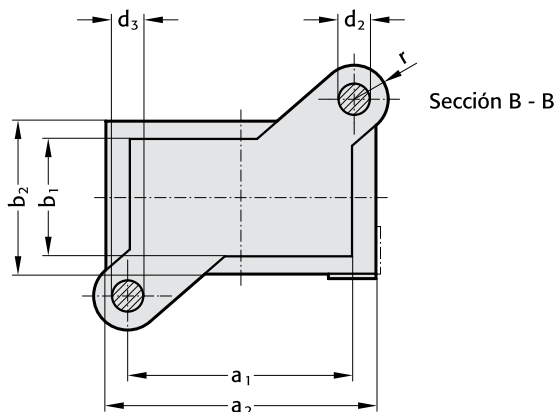
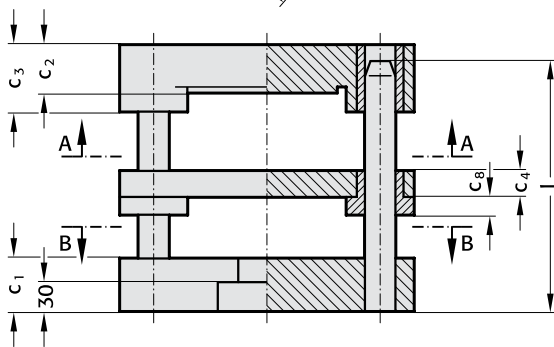
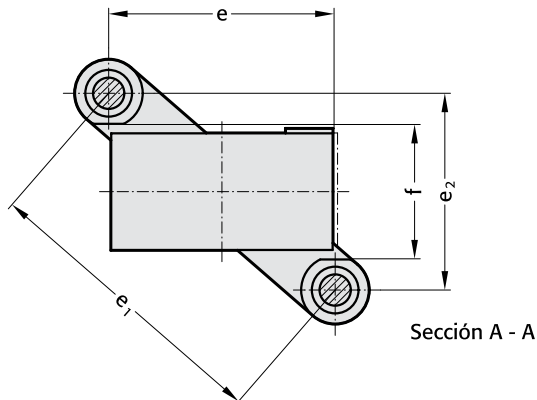

Modo de guiado

Guía con casquillo metal sinterizado carbonitrurado

Guía a bolas

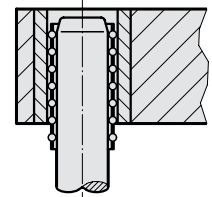
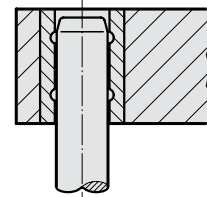

A elegir con placa intermedia

acero

acero

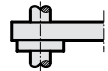

Código, parte II
A elegir con o sin taladro para tirante en la parte superior

.034

.054

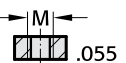
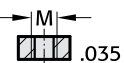

201.23.

Código parte I	Superf. trabajo a ₁ x b ₁	a ₂	b ₂	c ₁	c ₂	c ₃	c ₄	c ₈	d ₂	d ₃	e	e ₁	e ₂	f	l	r	M
201.23.100.080	100 x 80	140	120	50	30	50	22	18	25	24	100	175	144	98	160	30	20x1,5
125.100	125 x 100	165	140	50	40	60	22	18	25	24	125	206	164	118	160	30	24x1,5
160.100	160 x 100	200	140	50	40	60	22	18	25	24	160	229	164	118	160	30	24x1,5
125	160 x 125	200	165	56	40	60	27	18	32	30	160	259	204	148	180	37	24x1,5
201.23.200.125	200 x 125	240	165	56	40	60	27	18	32	30	200	286	204	148	180	37	24x1,5
250.160	250 x 160	290	200	56	50	70	27	18	32	30	250	346	240	184	200	37	30x2

Ejemplo de pedido:

Portamatrices = 201.23.
 Superf. trabajo 160 x 100 mm = 160.100.
 Guía sinterizado, placa intermedia acero,
 sin taladro roscado para tirante = 034
 Código = 201.23.160.100.034



201.26.

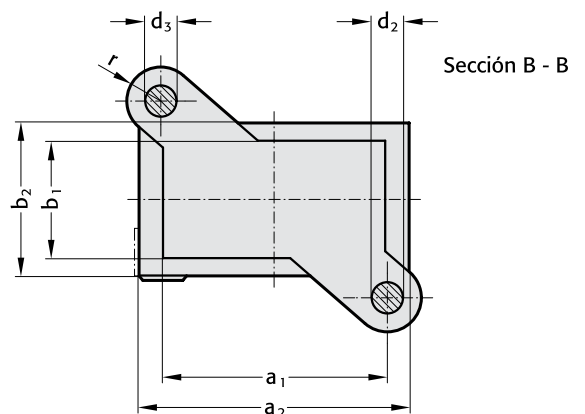
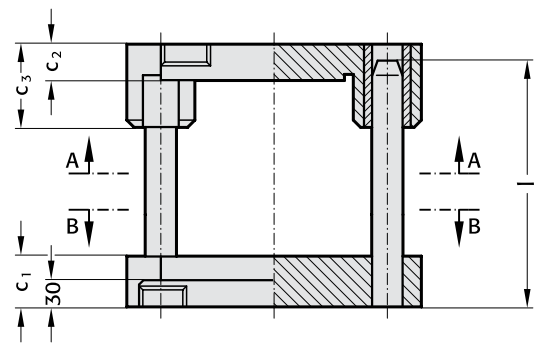
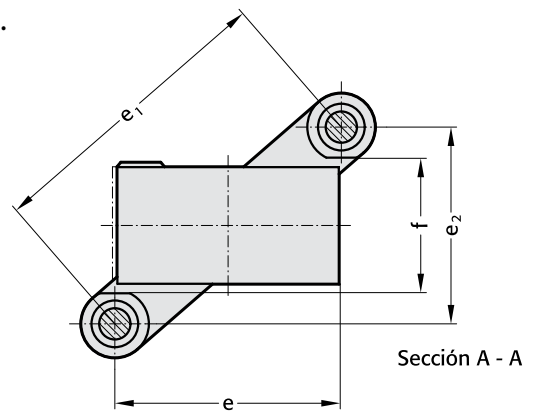

Modo de guiado

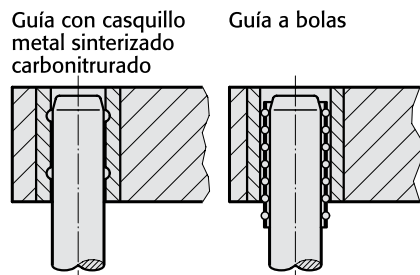

Código, parte II
A elegir con o sin taladro roscado para tirante en placa superior

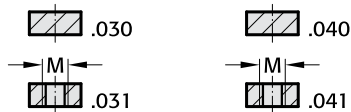

201.26.

Código parte I	Superf. trabajo		C ₁	C ₂	C ₃	d ₂	d ₃	e	e ₁	e ₂	f	l	r	M
	a ₁ x b ₁	a ₂ b ₂												
201.26.125.100	125 x 100	165 140	50	40	90	25	24	125	206	164	110	160	30	24x1,5
160.100	160 x 100	200 140	50	40	90	25	24	160	229	164	110	160	30	24x1,5
125	160 x 125	200 165	56	40	90	32	30	160	259	204	139	180	37	24x1,5
201.26.200.125	200 x 125	240 165	56	40	90	32	30	200	286	204	139	180	37	24x1,5
160	200 x 160	240 200	56	50	100	32	30	200	312	240	174	200	37	30x2

Ejemplo de pedido:

Portamatrices = 201.26.
 Superf. trabajo 160 x 125 mm = 160.125.
 Casq. guía sinter. con taladro roscado para tirante = 031
 Código = 201.26.160.125.031

FIBRO

201.31.

Portamatrices de fundición, DIN 9822 forma C

201.31.

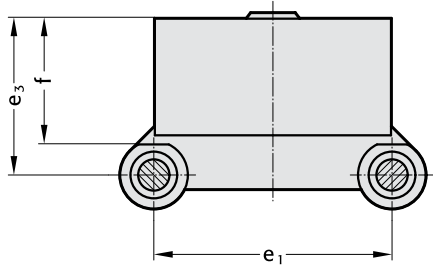

Sección A - A

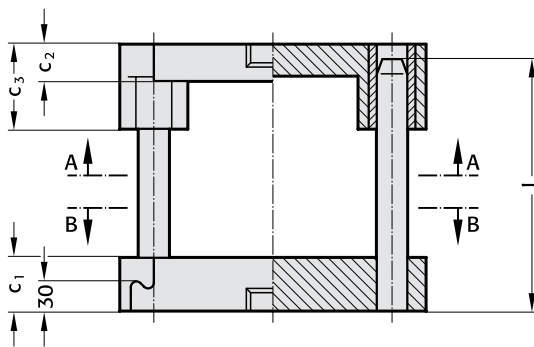

Sección B - B

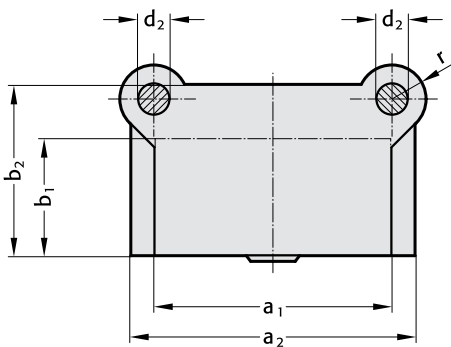

Modo de guiado

Guía con casquillo
metal sinterizado
carbonitrurado

Guía a bolas

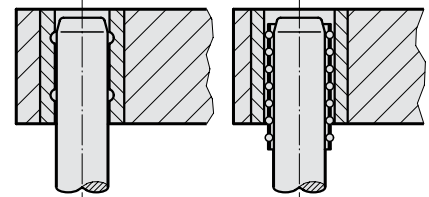

Código, parte II
Sin taladro roscado para tirante en placa superior



201.31.

Código parte I	Superf. trabajo a ₁ x b ₁											
		a ₂	b ₂	c ₁	c ₂	c ₃	d ₂	e ₁	e ₃	f	l	r
201.31.063.050	63 x 50	95	84	40	25	50	20	72	77	55	140	22
080.063	80 x 63	125	105	45	30	60	20	80	92	68	160	27
100.063	100 x 63	145	105	45	30	60	20	100	92	68	160	27
080	100 x 80	145	130	50	30	70	25	100	112	87	160	30
201.31.125.080	125 x 80	170	130	50	30	70	25	125	112	87	160	30
160.080	160 x 80	205	130	50	30	70	25	160	112	87	160	30
125.100	125 x 100	170	150	56	40	90	32	125	140	107	180	37
160.100	160 x 100	205	150	56	40	90	32	160	140	107	180	37
200.100	200 x 100	245	150	56	40	90	32	200	140	107	180	37
160.125	160 x 125	215	180	56	40	90	32	160	165	132	180	37
200.125	200 x 125	255	180	56	40	90	32	200	165	132	180	37
250.125	250 x 125	305	180	56	40	90	32	250	165	132	180	37
200.160	200 x 160	255	225	63	50	90	40	200	210	167	224	48
250.160	250 x 160	305	225	63	50	120	40	250	210	167	224	48
200	250 x 200	305	270	63	50	120	50	250	260	207	224	56
201.31.315.250	315 x 250	370	320	63	50	120	50	315	310	257	224	56



201.33.

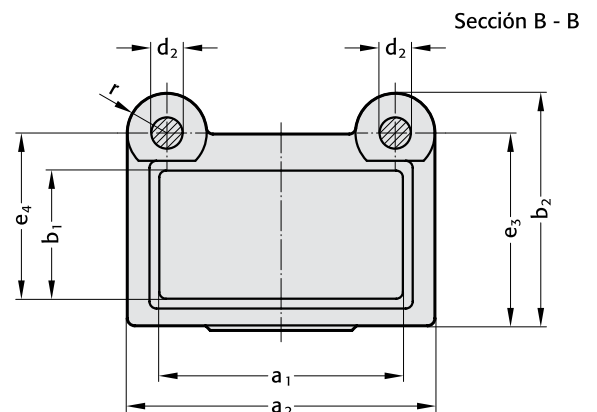
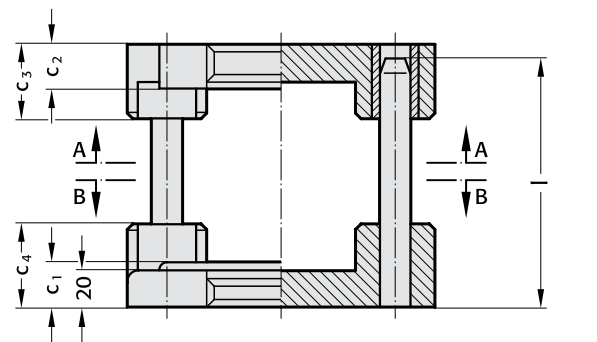
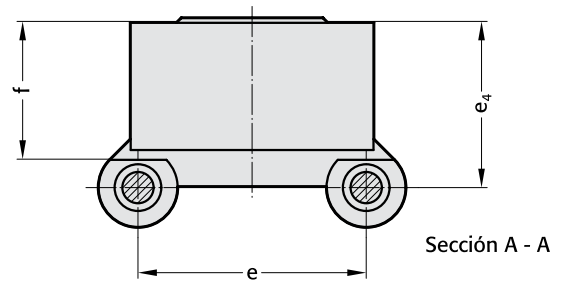

Modo de guiado

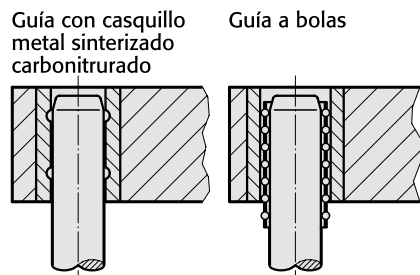

Código, parte II
Sin taladro roscado para tirante en placa superior



201.33.

Código parte I	Superf. trabajo $a_1 \times b_1$	a_2	b_2	c_1	c_2	c_3	c_4	d_2	e	e_3	e_4	f	l	r
201.33.063.050	63 x 50	116	110	25	25	40	45	16	72	88	74	57	125	22
080.060	80 x 60	116	117	25	25	40	45	20	72	95	81	62	160	22

Ejemplo de pedido:

Portamatrices = 201.33.
 Sup. trabajo 63 x 50 mm = 063.050.
 Casq. guía sinter. = 030
 Código = 201.33.063.050.030

FIBRO

201.36.

Portamatrices de fundición

201.36.

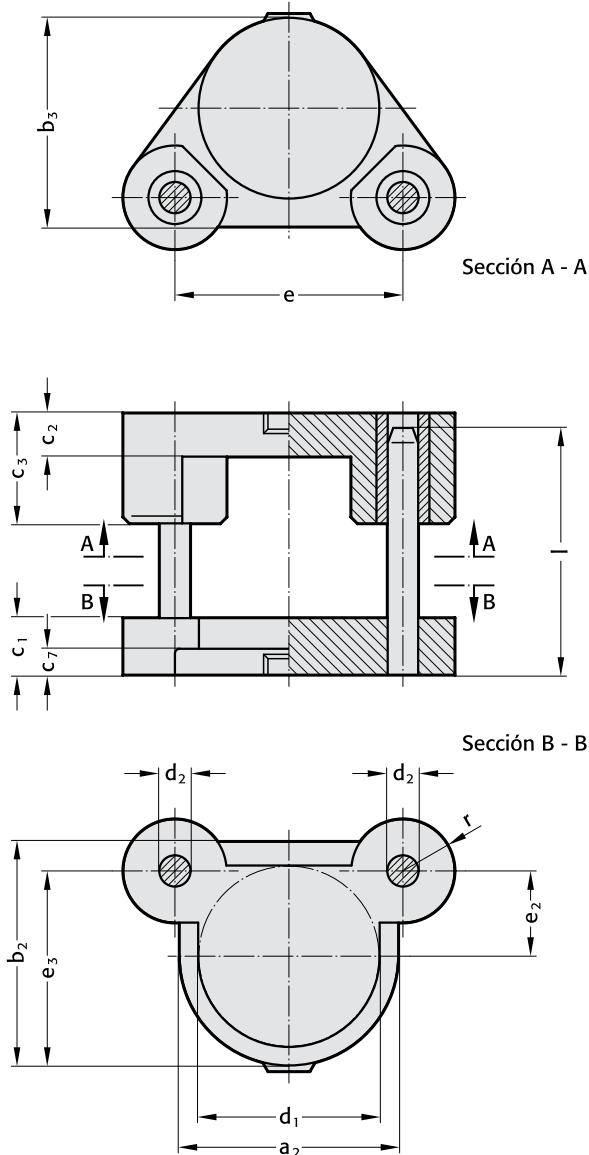

Modo de guiado

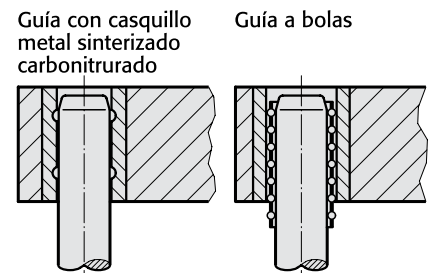

Código, parte II
Sin taladro roscado para tirante en placa superior

.030

.040

201.36.

Código parte I	Superf. trabajo													
	d ₁	a ₂	b ₂	b ₃	c ₁	c ₂	c ₃	c ₇	d ₂	e	e ₂	e ₃	l	r
201.36.050	50	80	80	65	40	30	50	25	20	66	33	73	125	20
063	63	94	94	78	45	30	60	25	20	82	41	88	125	25
080	80	110	110	95	50	30	70	30	25	105	52	107	160	30
100	100	140	140	120	50	30	70	30	25	125	57	127	160	30
125	125	166	166	145	56	40	90	30	32	157	73	156	180	38
160	160	200	200	180	63	50	120	30	40	200	85	185	224	48
180	180	220	220	200	63	50	120	30	40	224	90	200	224	48
200	200	250	250	225	63	50	120	30	50	250	95	220	224	56
250	250	300	300	275	63	50	120	30	50	300	120	270	224	56

Ejemplo de pedido:

Portamatrices	= 201.36.
Sup. de trabajo 125 mm	= 125.
Casq. guía sinter.	= 030
Código	= 201.36.125.030

Portamatrices de fundición para corte fino

201.39.

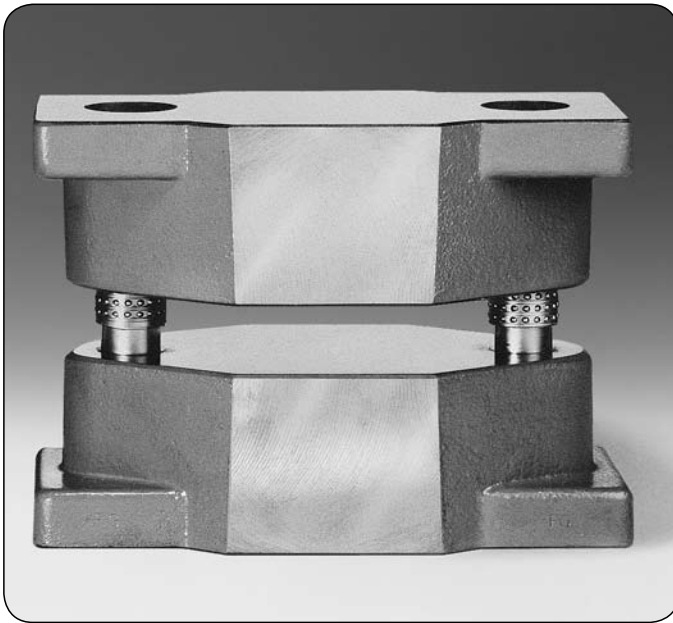

201.39.

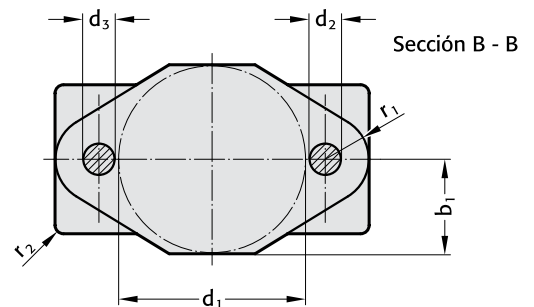
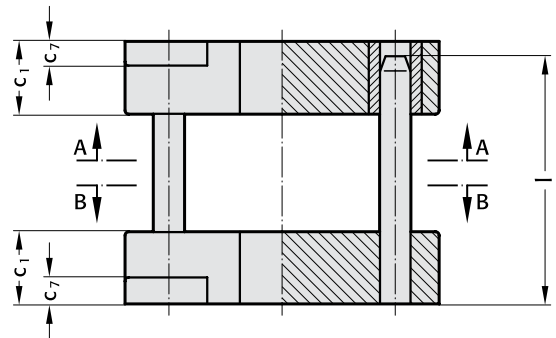
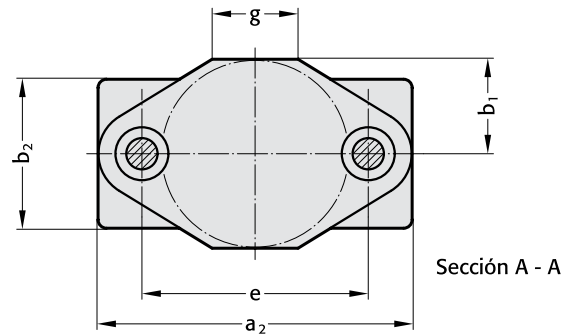

Las caras laterales son mecanizadas paralelamente una vez ensamblado el portamatrices, de manera que es posible montar y probar los utilajes en una posición horizontal sobre un mármol.

Modo de guiado

Guía a bolas

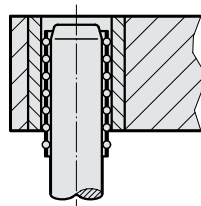

Código, parte II
Sin taladro roscado para tirante en placa superior.



201.39.

Código parte I	Superf. trabajo													
	d ₁	a ₂	b ₁	b ₂	c ₁	c ₇	d ₂	d ₃	e	g	l	r ₁	r ₂	
201.39.100	100	220	50	85	75	22	25	24	140	60	140	27	6	
125	125	245	62	100	75	25	25	24	165	80	140	27	6	
160	160	290	80	140	75	25	32	30	200	80	140	35	6	
200	200	340	100	160	80	30	40	38	250	90	160	45	8	
250	250	400	125	200	85	32	40	38	300	100	180	50	10	

Ejemplo de pedido:

Portamatrices = 201.39.

Superf. trabajo 160 mm = 160.

Guía a bolas = 040

Código = 201.39.160.040

Portamatrices de acero y aluminio guiados por columnas

FIBRO

2010.45. 2010.47.
2010.46. 2010.49.

Portamatrices a columnas standard con placas de acero, símil a DIN 9868/ISO 11415 sin placas intermedias

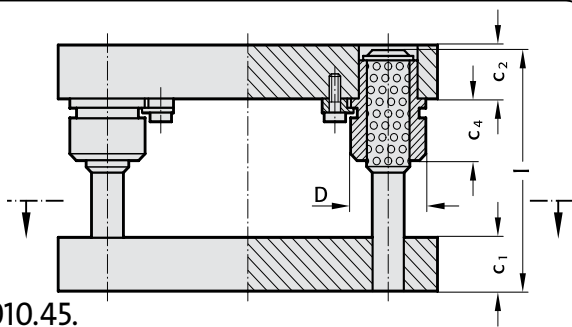

2010.45.

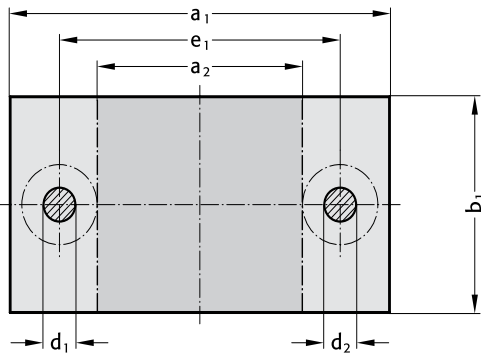

2010.46.

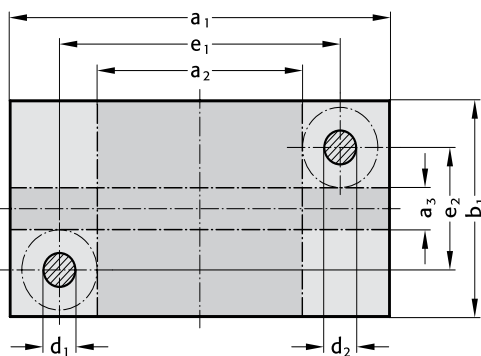

2010.47.

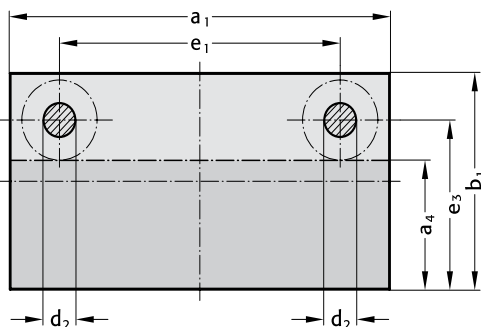

2010.49.

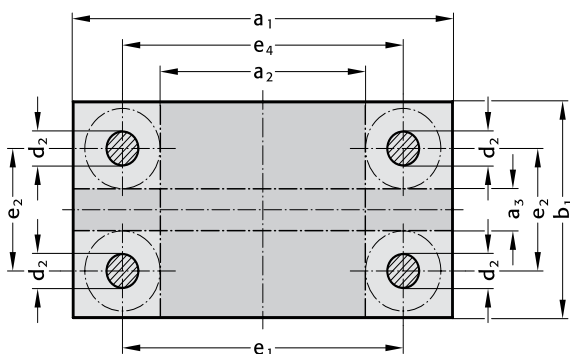

Tipos de guiado standard

Casquillo con valona sinterizado carbonitrurado.

Casquillo con valona, con guía a bolas.

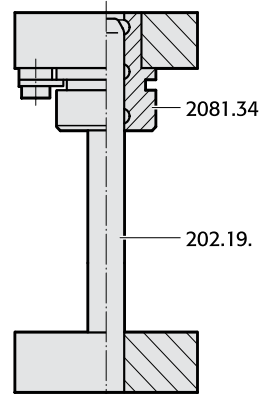

2010.□□.□□□□.□.834.

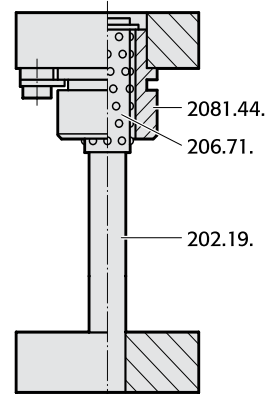

2010.□□.□□□□.□.862.

Descripción:

Los portamatrices de acero FIBRO se suministran en ejecución standard con casquillos con valona, sean éstos sinterizados carbonitrurados o guiados a bolas. Los casquillos son montados con ajuste suave de gran precisión y sujetos por bridas. A cada medida de diámetro de columna, los casquillos correspondientes, sean sinterizados o guiados a bolas, tienen el mismo diámetro exterior. Esto facilita la intercambiabilidad, combinaciones y se aprovecha el material al máximo.

Sobre demanda, todos los portamatrices standard pueden ser suministrados con otros tipos de guía (véanse «combinaciones posibles») en página A30, o bien en ejecuciones especiales.

Execución:

Contornos exteriores fresados
Superfs planas de grosor rectificadas

a_1 o $b_1 \leq 630 = \begin{matrix} +0,4 \\ +0,2 \end{matrix}$
 a_1 o $b_1 > 630 = \begin{matrix} +0,6 \\ +0,2 \end{matrix}$

Ejemplos de pedido:
Vea página desplegable opuesta.

Portamatrices a columnas standard con placas de acero, símil a DIN 9868/ISO 11415 con placas intermedias

FIBRO

2010.45. 2010.46.
2010.49.

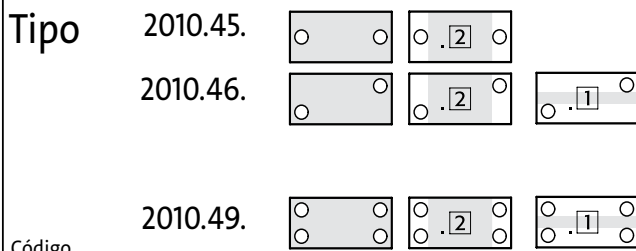

Código	Parte	.I	.II	.III	.IV	.V	Medidas ext. a ₁ × b ₁	Superf. trabajo a ₂ × b ₁	Superf. trabajo a ₁ × a ₃	C ₁ ±2	C ₂ ±2	C ₃ ±2	C ₄	C ₅	d ₁ /d ₂ × l	D	e ₁	e ₂	e ₄	
Tipo	Tamaño	Tipo	C* guía																	
2010.	.1608.1.						160 × 80	60 × 80	-	32	32	25	12	12	19/20 × 180	39	100	-	-	
	.1610.1.						160 × 100	60 × 100	-	32	32	25	12	12	19/20 × 180	39	100	-	-	
	.1612.1.						160 × 125	60 × 125	-	32	32	25	12	12	19/20 × 180	39	100	-	-	
	.1616.1.						160 × 160	60 × 160	160 × 60	32	32	25	12	12	19/20 × 180	39	100	100	103	
2010.	.2010.1.						200 × 100	70 × 100	-	40	40	25	25	12	24/25 × 200	46	120	-	-	
	.2010.2.									40	32									
	.2010.3.									32	40									
	.2010.4.									32	32									
2010.	.2012.1.						200 × 125	70 × 125	-	40	40	25	25	12	24/25 × 200	46	120	-	-	
	.2012.2.									40	32									
	.2012.3.									32	40									
	.2012.4.									32	32									
2010.	.2016.1.						200 × 160	70 × 160	-	40	40	25	25	12	24/25 × 200	46	120	-	-	
	.2016.2.									40	32									
	.2016.3.									32	40									
	.2016.4.									32	32									
2010.	.2020.1.						200 × 200	70 × 200	200 × 70	40	40	25	25	12	24/25 × 200	46	120	120	123	
	.2020.2.									40	32									
	.2020.3.									32	40									
	.2020.4.									32	32									
2010.	.2512.1.						250 × 125	120 × 125	-	40	40	25	25	12	24/25 × 200	46	170	-	-	
	.2512.2.									40	32									
	.2512.3.									32	40									
	.2512.4.									32	32									
2010.	.2516.1.						250 × 160	120 × 160	-	40	40	25	25	12	24/25 × 200	46	170	-	-	
	.2516.2.									40	32									
	.2516.3.									32	40									
	.2516.4.									32	32									
2010.	.2520.1.						250 × 200	120 × 200	250 × 70	40	40	25	25	12	24/25 × 200	46	170	120	173	
	.2520.2.									40	32									
	.2520.3.									32	40									
	.2520.4.									32	32									
2010.	.2525.1.						250 × 250	120 × 250	250 × 120	40	40	25	25	12	24/25 × 200	46	170	170	173	
	.2525.2.									40	32									
	.2525.3.									32	40									
	.2525.4.									32	32									
2010.	.3116.1.						315 × 160	165 × 160	-	50	50	32	32	12	30/32 × 224	53	225	-	-	
	.3116.2.									50	40									
	.3116.3.									40	50									
	.3116.4.									40	40									
2010.	.3120.1.						315 × 200	165 × 200	315 × 50	50	50	32	32	12	30/32 × 224	53	225	110	228	
	.3120.2.									50	40									
	.3120.3.									40	50									
	.3120.4.									40	40									
2010.	.3125.1.						315 × 250	165 × 250	315 × 100	50	50	32	32	12	30/32 × 224	53	225	160	228	
	.3125.2.									50	40									
	.3125.3.									40	50									
	.3125.4.									40	40									
2010.	.3131.1.						315 × 315	165 × 315	315 × 165	50	50	32	32	12	30/32 × 224	53	225	225	228	
	.3131.2.									50	40									
	.3131.3.									40	50									
	.3131.4.									40	40									
2010.	.4020.1.						400 × 200	250 × 200	400 × 50	50	50	32	32	12	30/32 × 224	53	310	110	313	
	.4020.2.									50	40									
	.4020.3.									40	50									
	.4020.4.									40	40									
2010.	.4025.1.						400 × 250	250 × 250	400 × 100	50	50	32	32	12	30/32 × 224	53	310	160	313	
	.4025.2.									50	40									
	.4025.3.									40	50									
	.4025.4.									40	40									
2010.	.4031.1.						400 × 315	250 × 315	400 × 165	50	50	32	32	12	30/32 × 224	53	310	225	313	
	.4031.2.									50	40									
	.4031.3.									40	50									
	.4031.4.									40	40									

Portamatrices a columnas standard con placas de acero, similar a DIN 9868/ISO 11415 con placas intermedias

FIBRO

2010.45. 2010.46.
2010.49.







Código	Parte	.I	.II	.III.IV	.V	Medidas ext.	Superf. trabajo	Superf. trabajo	c_1	c_2	c_3	c_4	c_5	$d_1/d_2 \times l$	D	e_1	e_2	e_4
Tipo	Tamaño	C*	Tipo	guía		$a_1 \times b_1$	$a_2 \times b_1$	$a_1 \times a_3$	± 2	± 2	± 2							
2010.	4040.1.					400 × 400	250 × 400	400 × 250	50	50	32	32	12	30/32 × 224	53	310	310	313
	4040.2.								50	40								
	4040.3.								40	50								
	4040.4.								40	40								
2010.	5025.1.					500 × 250	330 × 250	500 × 80	50	50	32	32	15	38/40 × 224	63	400	150	403
	5025.2.								50	40								
	5025.3.								40	50								
	5025.4.								40	40								
2010.	5031.1.					500 × 315	330 × 315	500 × 145	50	50	32	32	15	38/40 × 224	63	400	215	403
	5031.2.								50	40								
	5031.3.								40	50								
	5031.4.								40	40								
2010.	5040.1.					500 × 400	330 × 400	500 × 230	50	50	32	32	15	38/40 × 224	63	400	300	403
	5040.2.								50	40								
	5040.3.								40	50								
	5040.4.								40	40								
2010.	5050.1.					500 × 500	330 × 500	500 × 330	50	50	32	32	15	38/40 × 224	63	400	400	403
	5050.2.								50	40								
	5050.3.								40	50								
	5050.4.								40	40								
2010.	6331.1.					630 × 315	430 × 315	630 × 115	63	63	40	36	18	48/50 × 280	77	510	195	513
	6331.2.								63	50				48/50 × 280				
	6331.3.								50	63				48/50 × 250				
	6331.4.								50	50				48/50 × 250				
2010.	6340.1.					630 × 400	430 × 400	630 × 200	63	63	40	36	18	48/50 × 280	77	510	280	513
	6340.2.								63	50				48/50 × 280				
	6340.3.								50	63				48/50 × 250				
	6340.4.								50	50				48/50 × 250				
2010.	6350.1.					630 × 500	430 × 500	630 × 300	63	63	40	36	18	48/50 × 280	77	510	380	513
	6350.2.								63	50				48/50 × 280				
	6350.3.								50	63				48/50 × 250				
	6350.4.								50	50				48/50 × 250				
2010.	6363.1.					630 × 630	430 × 630	630 × 430	63	63	40	36	18	48/50 × 280	77	510	510	513
	6363.2.								63	50				48/50 × 280				
	6363.3.								50	63				48/50 × 250				
	6363.4.								50	50				48/50 × 250				
2010.	7140.1.					710 × 400	510 × 400	710 × 200	63	63	40	36	18	48/50 × 280	77	590	280	593
	7140.2.								63	50				48/50 × 280				
	7140.3.								50	63				48/50 × 250				
	7140.4.								50	50				48/50 × 250				
2010.	7150.1.					710 × 500	510 × 500	710 × 300	63	63	40	36	18	48/50 × 280	77	590	380	593
	7150.2.								63	50				48/50 × 280				
	7150.3.								50	63				48/50 × 250				
	7150.4.								50	50				48/50 × 250				
2010.	7163.1.					710 × 630	510 × 630	710 × 430	63	63	40	36	18	48/50 × 280	77	590	510	593
	7163.2.								63	50				48/50 × 280				
	7163.3.								50	63				48/50 × 250				
	7163.4.								50	50				48/50 × 250				
2010.	8040.1.					800 × 400	600 × 400	800 × 200	63	63	40	36	18	48/50 × 280	77	680	280	683
	8040.2.								63	50				48/50 × 280				
	8040.3.								50	63				48/50 × 250				
	8040.4.								50	50				48/50 × 250				
2010.	8050.1.					800 × 500	600 × 500	800 × 300	63	63	40	36	18	48/50 × 280	77	680	380	683
	8050.2.								63	50				48/50 × 280				
	8050.3.								50	63				48/50 × 250				
	8050.4.								50	50				48/50 × 250				
2010.	8063.1.					800 × 630	600 × 630	800 × 430	63	63	40	36	18	48/50 × 280	77	680	510	683
	8063.2.								63	50				48/50 × 280				
	8063.3.								50	63				48/50 × 250				
	8063.4.								50	50				48/50 × 250				

*C. = Combinación de espesores de placa

Ejemplo de pedido:

Portamatrices modelo = 2010.45.
 Tamaño = 400x250 = 4025.
 Emparejamiento $c_1 = 50, c_2 = 50$ = 1.
 Tipo de guía – casquillo sinterizado, con valona = 835.
 Superf. trabajo 2 = 2
 Código = 2010.45.4025.1.835.2

Nota:

La disposición de las bridas depende de la posición de la superficie de trabajo, que debe especificarse en la sección V del código de pedido, por ejemplo 2010.49.2520.4.865.1      

FIBRO

2010.45. 2010.47.
2010.46. 2010.49.

Portamatrices a columnas standard con placas de acero, similar a DIN 9868/ISO 11415 sin placas intermedias



Código																			
Parte	.I	.II	.III	.IV	.V	Medidas ext.	Superf. trabajo	Superf. trabajo	Superf. trabajo	c_1	c_2	c_4	c_4	$d_1/d_2 \times l$	D	e_1	e_2	e_3	e_4
Tipo	Tamaño	C*	Tipo	guía		$a_1 \times b_1$	$a_2 \times b_1$	$a_1 \times a_3$	$a_1 \times a_4$	± 2	± 2	S	K						
2010.	.4040.1.					400 × 400	250 × 400	400 × 250	400 × 325	50	50	45	63	30/32 × 200	53	310	310	355	313
	.4040.2.									50	40								
	.4040.3.									40	50								
	.4040.4.									40	40								
2010.	.5025.1.					500 × 250	330 × 250	500 × 80	500 × 165	50	50	45	71	38/40 × 200	63	400	150	200	403
	.5025.2.									50	40								
	.5025.3.									40	50								
	.5025.4.									40	40								
2010.	.5031.1.					500 × 315	330 × 315	500 × 145	500 × 230	50	50	45	71	38/40 × 200	63	400	215	265	403
	.5031.2.									50	40								
	.5031.3.									40	50								
	.5031.4.									40	40								
2010.	.5040.1.					500 × 400	330 × 400	500 × 230	500 × 315	50	50	45	71	38/40 × 200	63	400	300	350	403
	.5040.2.									50	40								
	.5040.3.									40	50								
	.5040.4.									40	40								
2010.	.5050.1.					500 × 500	330 × 500	500 × 330	500 × 415	50	50	45	71	38/40 × 200	63	400	400	450	403
	.5050.2.									50	40								
	.5050.3.									40	50								
	.5050.4.									40	40								
2010.	.6331.1.					630 × 315	430 × 315	630 × 115	630 × 215	63	63	50	80	48/50 × 250	77	510	195	255	513
	.6331.2.									63	50			48/50 × 250					
	.6331.3.									50	63			48/50 × 224					
	.6331.4.									50	50			48/50 × 224					
2010.	.6340.1.					630 × 400	430 × 400	630 × 200	630 × 300	63	63	50	80	48/50 × 250	77	510	280	340	513
	.6340.2.									63	50			48/50 × 250					
	.6340.3.									50	63			48/50 × 224					
	.6340.4.									50	50			48/50 × 224					
2010.	.6350.1.					630 × 500	430 × 500	630 × 300	630 × 400	63	63	50	80	48/50 × 250	77	510	380	440	513
	.6350.2.									63	50			48/50 × 250					
	.6350.3.									50	63			48/50 × 224					
	.6350.4.									50	50			48/50 × 224					
2010.	.6363.1.					630 × 630	430 × 630	630 × 430	630 × 530	63	63	50	80	48/50 × 250	77	510	510	570	513
	.6363.2.									63	50			48/50 × 250					
	.6363.3.									50	63			48/50 × 224					
	.6363.4.									50	50			48/50 × 224					
2010.	.7140.1.					710 × 400	510 × 400	710 × 200	710 × 300	63	63	50	80	48/50 × 250	77	590	280	340	593
	.7140.2.									63	50			48/50 × 250					
	.7140.3.									50	63			48/50 × 224					
	.7140.4.									50	50			48/50 × 224					
2010.	.7150.1.					710 × 500	510 × 500	710 × 300	710 × 400	63	63	50	80	48/50 × 250	77	590	380	440	593
	.7150.2.									63	50			48/50 × 250					
	.7150.3.									50	63			48/50 × 224					
	.7150.4.									50	50			48/50 × 224					
2010.	.7163.1.					710 × 630	510 × 630	710 × 430	710 × 530	63	63	50	80	48/50 × 250	77	590	510	570	593
	.7163.2.									63	50			48/50 × 250					
	.7163.3.									50	63			48/50 × 224					
	.7163.4.									50	50			48/50 × 224					
2010.	.8040.1.					800 × 400	600 × 400	800 × 200	800 × 300	63	63	50	80	48/50 × 250	77	680	280	340	683
	.8040.2.									63	50			48/50 × 250					
	.8040.3.									50	63			48/50 × 224					
	.8040.4.									50	50			48/50 × 224					
2010.	.8050.1.					800 × 500	600 × 500	800 × 300	800 × 400	63	63	50	80	48/50 × 250	77	680	380	440	683
	.8050.2.									63	50			48/50 × 250					
	.8050.3.									50	63			48/50 × 224					
	.8050.4.									50	50			48/50 × 224					
2010.	.8063.1.					800 × 630	600 × 630	800 × 430	800 × 530	63	63	50	80	48/50 × 250	77	680	510	570	683
	.8063.2.									63	50			48/50 × 250					
	.8063.3.									50	63			48/50 × 224					
	.8063.4.									50	50			48/50 × 224					

*C. = Combinación de espesores de placa

Ejemplo de pedido:

Portamatrices modelo = 2010.45.
Medidas ext. = 400 × 250 = 4025.
Emparejamiento $c_1 = 50, c_2 = 50$ = 1.
Tipo de guía – casquillo sinterizado, con valona = 834.
Superf. trabajo 2 = 2
Código = 2010.45.4025.1.834.2

Nota:

La disposición de las bridas depende de la posición de la superficie de trabajo, que debe especificarse en la sección V del código de pedido, por ejemplo 2010.49.2520.4.862.1 
.2 

Portamatrices a columnas standard con placas de acero, símil a DIN 9868/ISO 11415 con placas intermedias

FIBRO

2010.45. 2010.46.
2010.49.

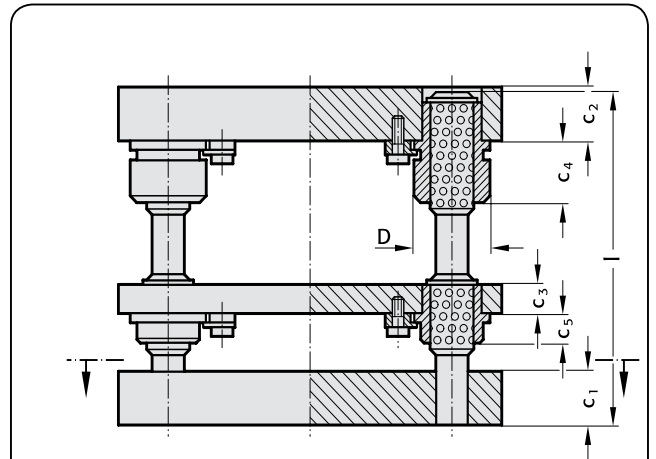

2010.45.

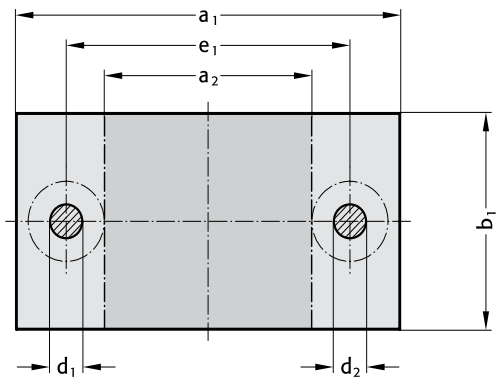

2010.46.

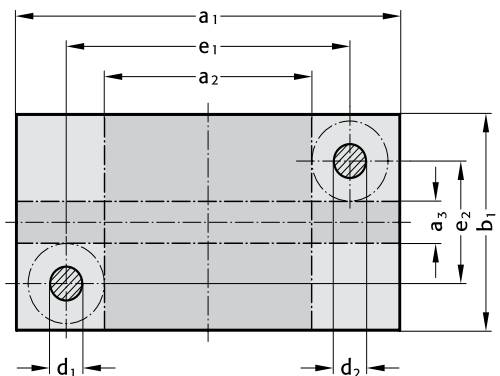

2010.49.

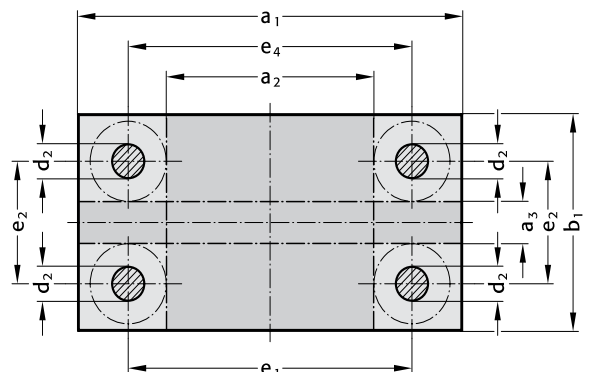

Tipos de guiado standard

Casquillo con valona sinterizado, carbonitrurado

Casquillo con valona con guía a bolas

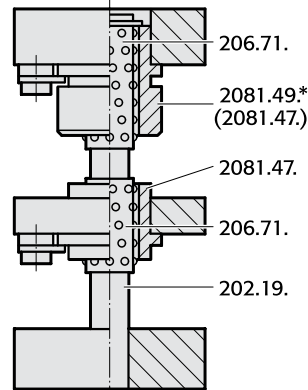
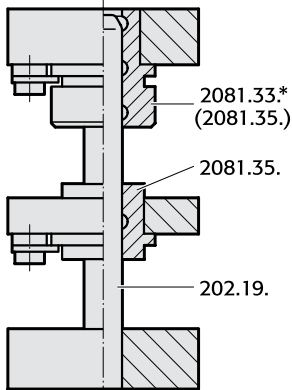

Código parte IV
2010.□□.□□□□.□.835.

Código parte IV
2010.□□.□□□□.□.865.

* Hasta tamaño 2010.□□.1616. = 2081.35./2081.47.

Descripción:

Las portamatrices de acero FIBRO con placas intermedias se suministran en ejecución standard con casquillos con valona, sean éstos sinterizados carbonitrurados o guiados a bolas. Los casquillos son montados con ajuste suave de gran precisión y sujetos por bridas. A cada medida de diámetro de columna, los casquillos correspondientes, sean sinterizados o guiados a bolas, tienen el mismo diámetro exterior. Esto facilita la intercambiabilidad, combinaciones y se aprovecha el material al máximo.

Sobre demanda, todos los portamatrices standard pueden ser suministrados con otros tipos de guía (véanse «combinaciones posibles» en página A 30), o bien en ejecuciones especiales.

Execución:

Contornos exteriores fresados
Superficies planas de grosor rectificadas

a_1 o $b_1 \leq 630$ = $\begin{matrix} +0,4 \\ +0,2 \end{matrix}$
 a_1 o $b_1 > 630$ = $\begin{matrix} +0,6 \\ +0,2 \end{matrix}$

Ejemplo de pedido vea página desplegable opuesta.

Portamatrices a suministrar según especificaciones del cliente
 Fotocopiar esta página, acotar medidas,
 rellenar cuestionario y devolver posteriormente a FIBRO.

FIBRO

201.45.

201.65.

Sin placa intermedia

Con placa intermedia

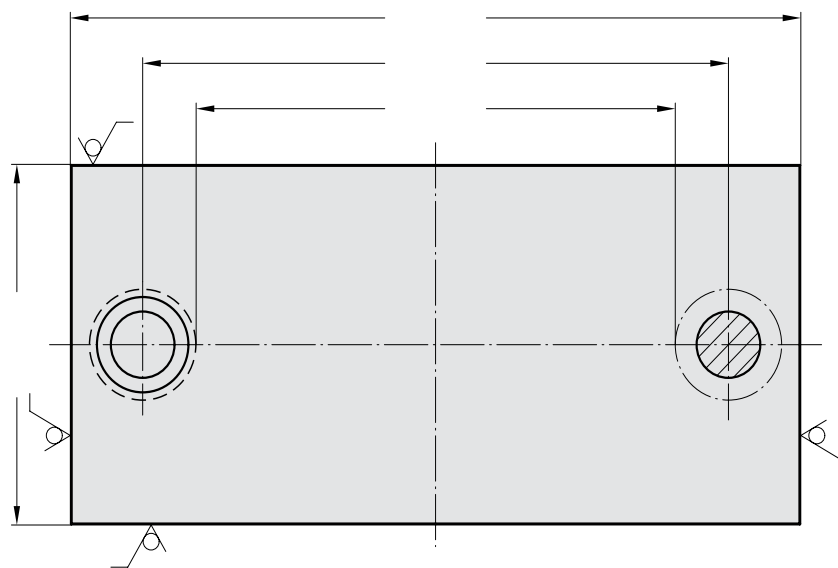
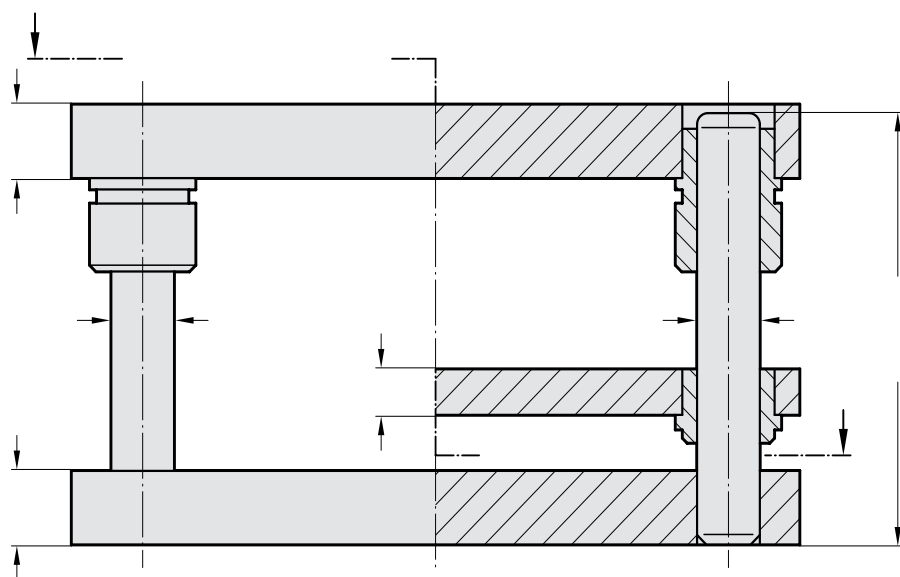

Columnas de guía

202.19. Columna de guía
 DIN 9825/ISO 9182-2

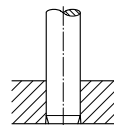

202.21. Columna de guía
 sujeción por tornillo

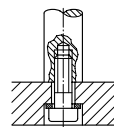

2021.46. Columna de guía
 intercambiable con
 sujeción por bridas,
 asiento de ajuste

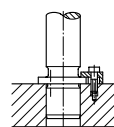

2021.46. Columna de guía
 intercambiable con
 sujeción por bridas,
 asiento de ajuste
 2021.43. Arandela
 con tornillo con
 cabeza cónica

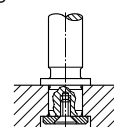

2021.50. Columna de guía
 intercambiable cónico,
 con casquillo de sujeción,
 asiento de ajuste
 2021.39. Casquillo
 de sujeción
 2021.53. Arandela de
 retención y tornillo
 con cabeza cónica

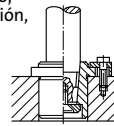

202.60. Columna de guía
 intercambiable
 con valona,
 sujeción central

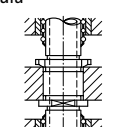

Casquillos de guía
 2031.34. Bloque de
 columna rectangular
 de guía sinterizado,
 carbonitrurado
 2031.42. Bloque de
 columna de guía,
 guía a bolas
 206.71. Jaulas a bolas

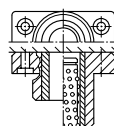

2031.38. Bloque de columna
 rectangular de guía,
 en ejecución corta,
 sinterizado,
 carbonitrurado
 2031.44. Bloque de
 columna de guía,
 guía a bolas
 206.71. Jaula a bolas

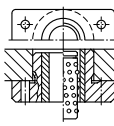

2051.32. Casquillo de guía
 sinterizado, carbonitrurado,
 pegado
 2061.44. Casquillo
 de guía, guía a bolas,
 pegado
 206.71. Jaula a bolas

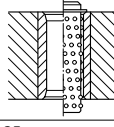

2081.31./32./33./34./35.
 Casquillos de guía con valona,
 guía sinterizado,
 carbonitrurado
 2081.44./45./46./
 47./49. Casquillos
 de guía con valona
 para guías a bolas
 206.71. Jaula a bolas

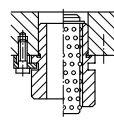

2091.31./32./34. Casquillos de
 guía con brida, guía sinterizado,
 carbonitrurado
 2091.44./45./46.
 Casquillos de guía
 con brida para guías
 a bolas, asiento de
 ajuste
 206.71. Jaulas a bolas

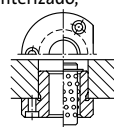

Solicitud de oferta Pedido

Material: Aleación de aluminio 201.65.

Acero 201.45.

Empresa

Teléfono

Persona a contactar

Firma y sello

FIBRO

201.46.
201.66.

Portamatrices a suministrar según especificaciones del cliente
Fotocopiar esta página, acotar medidas,
rellenar cuestionario y devolver posteriormente a FIBRO.

Columnas de guía
202.19
Columna de guía
DIN 9825/ISO 9182-2

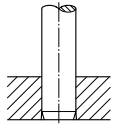

202.21. Columna de guía
sujeción por tornillo

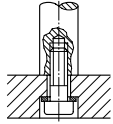

2021.46. Columna de guía
intercambiable con
sujeción por bridas,
asiento de ajuste

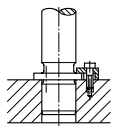

2021.46. Columna de guía
intercambiable con
sujeción por bridas,
asiento de ajuste
2021.43. Arandela
con tornillo con
cabeza cónica

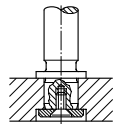

2021.50. Columna de guía
intercambiable cónico,
con casquillo de sujeción,
asiento de ajuste
2021.39. Casquillo
de sujeción
2021.53. Arandela de
retención y tornillo
con cabeza cónica

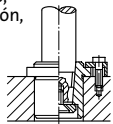

202.60. Columna de guía
intercambiable
con valona,
sujeción central

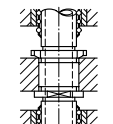

Casquillos de guía
2031.34. Bloque de
columna rectangular
de guía sinterizado,
carbonitrurado
2031.42. Bloque de
columna de guía,
guía a bolas
206.71. Jaulas a bolas

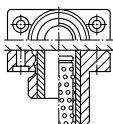

2031.38. Bloque de columna
rectangular de guía,
en ejecución corta,
sinterizado,
carbonitrurado
2031.44. Bloque de
columna de guía,
guía a bolas
206.71. Jaula a bolas

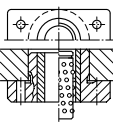

2051.32. Casquillo de guía
sinterizado, carbonitrurado,
pegado
2061.44. Casquillo
de guía, guía a bolas,
pegado
206.71. Jaula a bolas

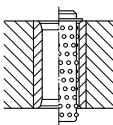

2081.31./32./33./34./35.
Casquillos de guía con valona,
guía sinterizado,
carbonitrurado
2081.44./45./46./
47./49. Casquillos
de guía con valona
para guías a bolas
206.71. Jaula a bolas

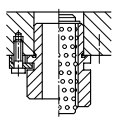

2091.31./32./34. Casquillos de
guía con brida, guía sinterizado,
carbonitrurado
2091.44./45./46.
Casquillos de guía
con brida para guías
a bolas, asiento de
ajuste
206.71. Jaulas a bolas

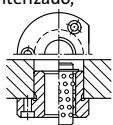

Sin placa intermedia

Con placa intermedia

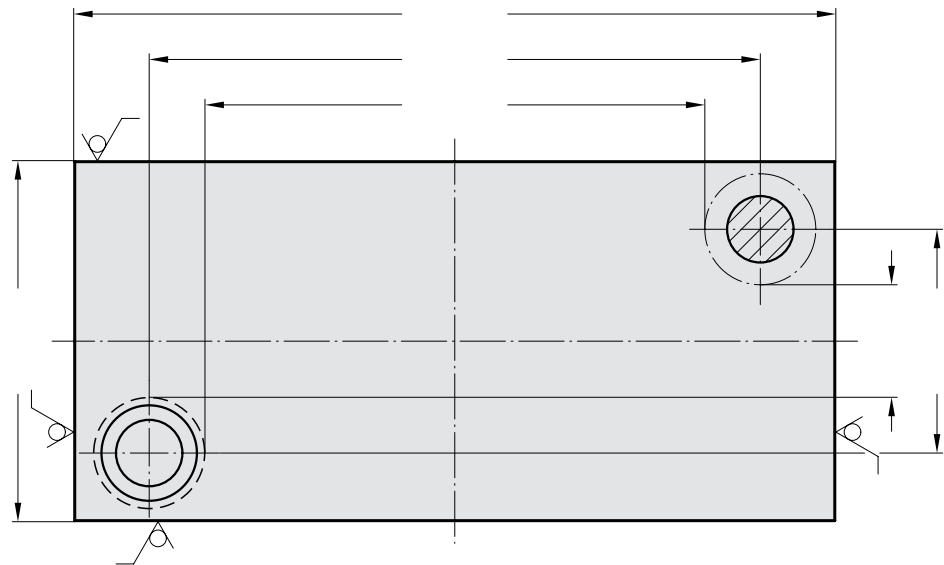
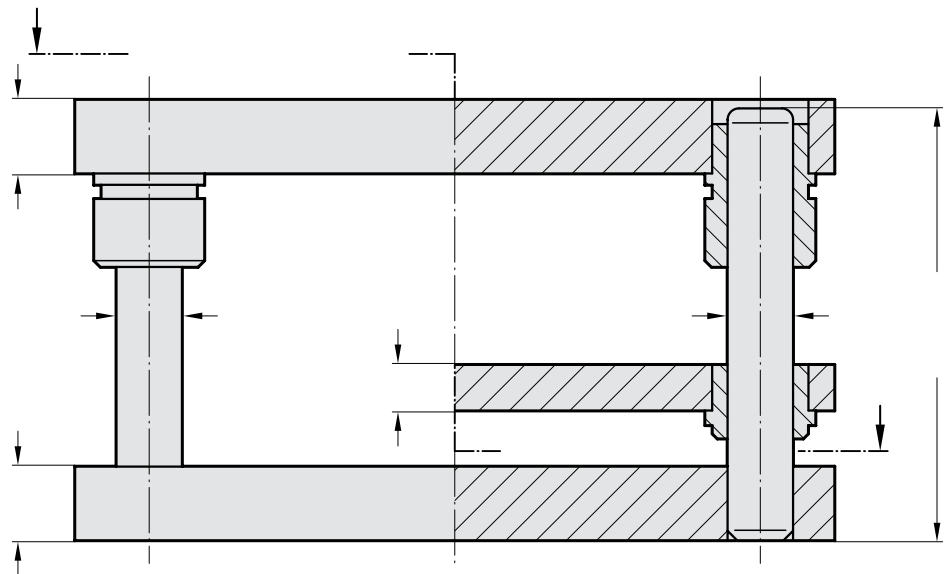

Solicitud de oferta Pedido

Material: Aleación de aluminio 201.66.

Acero 201.46.

Empresa

Teléfono

Persona a contactar

Firma y sello

Portamatrices a suministrar según especificaciones del cliente
 Fotocopiar esta página, acotar medidas,
 rellenar cuestionario y devolver posteriormente a FIBRO.

FIBRO

201.47.

201.67.

Sin placa intermedia

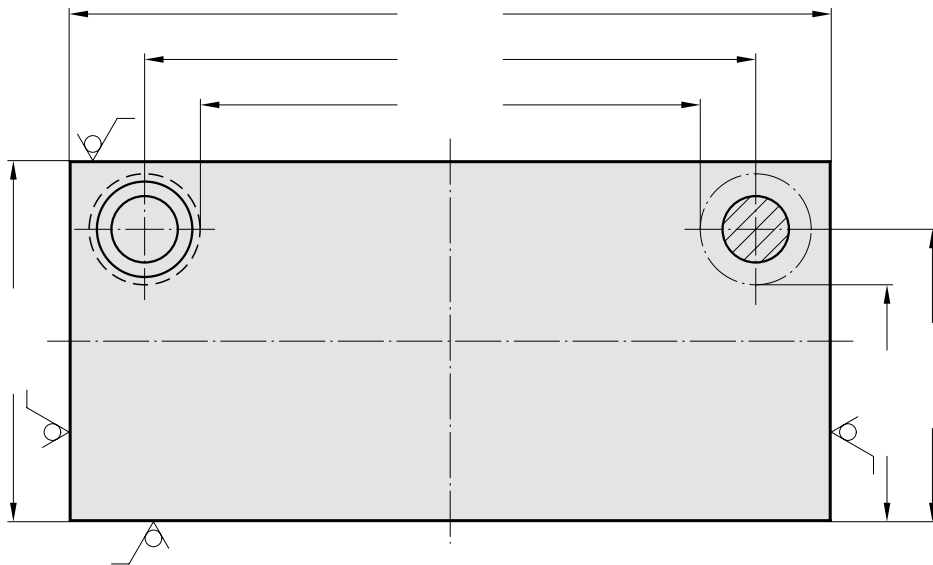
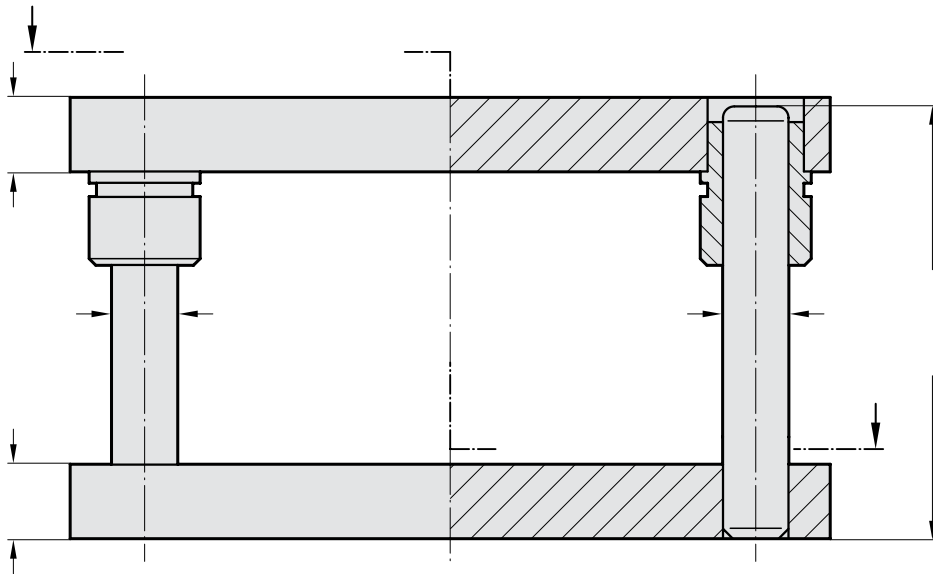

Columnas de guía

202.19
 Columna de guía
 DIN 9825/ISO 9182-2

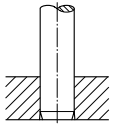

202.21. Columna de guía
 sujeción por tornillo

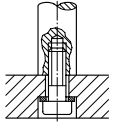

2021.46. Columna de guía
 intercambiable con
 sujeción por bridas,
 asiento de ajuste

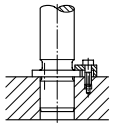

2021.46. Columna de guía
 intercambiable con
 sujeción por bridas,
 asiento de ajuste
 2021.43. Arandela
 con tornillo con
 cabeza cónica

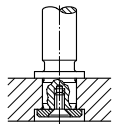

2021.50. Columna de guía
 intercambiable cónico,
 con casquillo de sujeción,
 asiento de ajuste
 2021.39. Casquillo
 de sujeción
 2021.53. Arandela de
 retención y tornillo
 con cabeza cónica

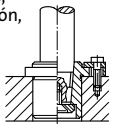

Casquillos de guía
 2031.34. Bloque de
 columna rectangular
 de guía sinterizado,
 carbonitrurado
 2031.42. Bloque de
 columna de guía,
 guía a bolas
 206.71. Jaulas a bolas

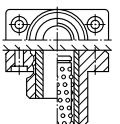

2031.38. Bloque de columna
 rectangular de guía,
 en ejecución corta,
 sinterizado,
 carbonitrurado
 2031.44. Bloque de
 columna de guía,
 guía a bolas
 206.71. Jaula a bolas

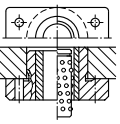

2051.32. Casquillo de guía
 sinterizado, carbonitrurado,
 pegado
 2061.44. Casquillo
 de guía, guía a bolas,
 pegado
 206.71. Jaula a bolas

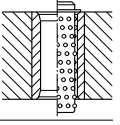

2081.31./32./33./34./35.
 Casquillos de guía con valona,
 guía sinterizado,
 carbonitrurado
 2081.44./45./46./
 47./49. Casquillos
 de guía con valona
 para guías a bolas
 206.71. Jaula a bolas

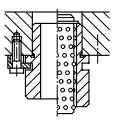

2091.31./32./34. Casquillos de
 guía con brida, guía sinterizado,
 carbonitrurado
 2091.44./45./46.
 Casquillos de guía
 con brida para guías
 a bolas, asiento de
 ajuste
 206.71. Jaulas a bolas



Solicitud de oferta Pedido

Material: Aleación aluminio 201.67.

Acero 201.47.

Empresa

Teléfono

Persona a contactar

Firma y sello

FIBRO

201.49.
201.69.

Portamatrices a suministrar según especificaciones del cliente
Fotocopiar esta página, acotar medidas,
rellenar cuestionario y devolver posteriormente a FIBRO.

Columnas de guía
202.19
Columna de guía
DIN 9825/ISO 9182-2

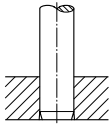

202.21. Columna de guía
sujeción por tornillo

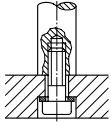

2021.46. Columna de guía
intercambiable con
sujeción por bridas,
asiento de ajuste

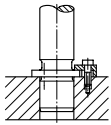

2021.46. Columna de guía
intercambiable con
sujeción por bridas,
asiento de ajuste
2021.43. Arandela
con tornillo con
cabeza cónica

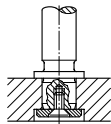

2021.50. Columna de guía
intercambiable cónico,
con casquillo de sujeción,
asiento de ajuste
2021.39. Casquillo
de sujeción
2021.53. Arandela de
retención y tornillo
con cabeza cónica

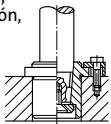

202.60. Columna de guía
intercambiable
con valona,
sujeción central

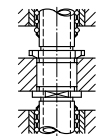

Casquillos de guía
2031.34. Bloque de
columna rectangular
de guía sinterizado,
carbonitrurado
2031.42. Bloque de
columna de guía,
guía a bolas
206.71. Jaulas a bolas

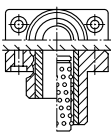

2031.38. Bloque de columna
rectangular de guía,
en ejecución corta,
sinterizado,
carbonitrurado
2031.44. Bloque de
columna de guía,
guía a bolas
206.71. Jaula a bolas

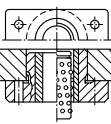

2051.32. Casquillo de guía
sinterizado, carbonitrurado,
pegado
2061.44. Casquillo
de guía, guía a bolas,
pegado
206.71. Jaula a bolas

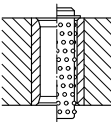

2081.31./32./33./34./35.
Casquillos de guía con valona,
guía sinterizado,
carbonitrurado
2081.44./45./46./
47./49. Casquillos
de guía con valona
para guías a bolas
206.71. Jaula a bolas

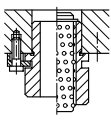

2091.31./32./34. Casquillos de
guía con brida, guía sinterizado,
carbonitrurado
2091.44./45./46.
Casquillos de guía
con brida para guías
a bolas, asiento de
ajuste
206.71. Jaulas a bolas

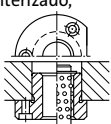

Sin placa intermedia

Con placa intermedia

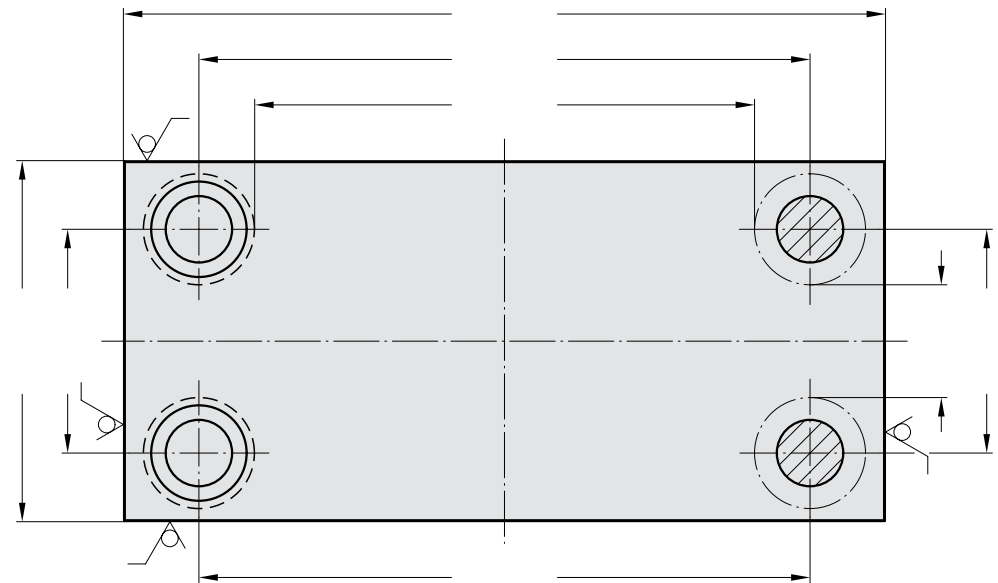
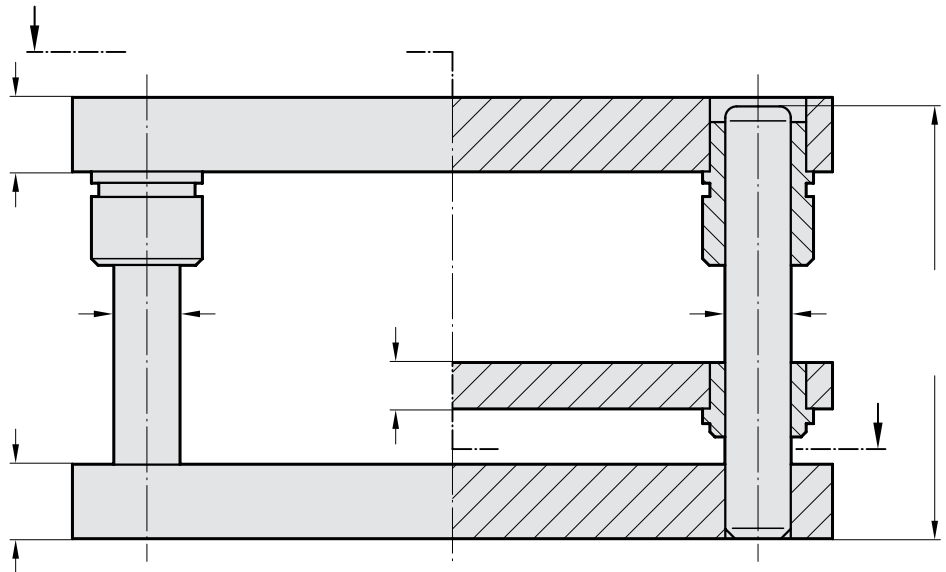

Solicitud de oferta Pedido

Material: Aleación aluminio 201.69. Acero 201.49.

Empresa _____ Teléfono _____

Persona a contactar _____ Firma y sello _____

Placas de acero ISO 6753-1

2900.

2900.

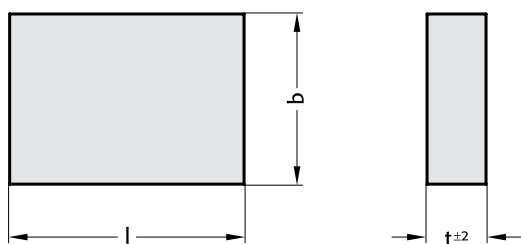

Ejecución: Contornos exteriores fresados
Superficies planas de grosor rectificadas

Nota:

$$l \text{ o } b \leq 630 = \begin{matrix} +0,4 \\ +0,2 \end{matrix}$$

$$l \text{ o } b > 630 = \begin{matrix} +0,6 \\ +0,2 \end{matrix}$$

Placas de medidas desde 500 x 500 mm se suministran con rosca para cáncamo.

Ejemplo de pedido:

Placa de acero	=	2900.
l x b = 400 x 400 mm	=	4040.
t = 32	=	32
Código	=	2900.4040.32

2900.

Código placa de acero	Tamaño l x b x t	Código placa de acero	Tamaño l x b x t	Código placa de acero	Tamaño l x b x t
2900.1608.25	160 x 80 x 25	2900.4025.32	400 x 250 x 32	50	710 x 630 x 50
32	160 x 80 x 32	40	400 x 250 x 40	63	710 x 630 x 63
2900.1610.25	160 x 100 x 25	50	400 x 250 x 50	2900.8040.32	800 x 400 x 32
32	160 x 100 x 32	2900.4031.32	400 x 315 x 32	40	800 x 400 x 40
2900.1612.25	160 x 125 x 25	40	400 x 315 x 40	50	800 x 400 x 50
32	160 x 125 x 32	50	400 x 315 x 50	63	800 x 400 x 63
2900.1616.25	160 x 160 x 25	2900.4040.32	400 x 400 x 32	2900.8050.32	800 x 500 x 32
32	160 x 160 x 32	40	400 x 400 x 40	40	800 x 500 x 40
2900.2010.25	200 x 100 x 25	50	400 x 400 x 50	50	800 x 500 x 50
32	200 x 100 x 32	2900.5025.32	500 x 250 x 32	63	800 x 500 x 63
40	200 x 100 x 40	40	500 x 250 x 40	2900.8063.32	800 x 630 x 32
2900.2012.25	200 x 125 x 25	50	500 x 250 x 50	40	800 x 630 x 40
32	200 x 125 x 32	2900.5031.32	500 x 315 x 32	50	800 x 630 x 50
40	200 x 125 x 40	40	500 x 315 x 40	63	800 x 630 x 63
2900.2016.25	200 x 160 x 25	50	500 x 315 x 50		
32	200 x 160 x 32	2900.5040.32	500 x 400 x 32		
40	200 x 160 x 40	40	500 x 400 x 40		
2900.2020.25	200 x 200 x 25	50	500 x 400 x 50		
32	200 x 200 x 32	2900.5050.32	500 x 500 x 32		
40	200 x 200 x 40	40	500 x 500 x 40		
2900.2512.25	250 x 125 x 25	50	500 x 500 x 50		
32	250 x 125 x 32	2900.6331.32	630 x 315 x 32		
40	250 x 125 x 40	40	630 x 315 x 40		
2900.2516.25	250 x 160 x 25	50	630 x 315 x 50		
32	250 x 160 x 32	63	630 x 315 x 63		
40	250 x 160 x 40	2900.6340.32	630 x 400 x 32		
2900.2520.25	250 x 200 x 25	40	630 x 400 x 40		
32	250 x 200 x 32	50	630 x 400 x 50		
40	250 x 200 x 40	63	630 x 400 x 63		
2900.2525.25	250 x 250 x 25	2900.6350.32	630 x 500 x 32		
32	250 x 250 x 32	40	630 x 500 x 40		
40	250 x 250 x 40	50	630 x 500 x 50		
2900.3116.32	315 x 160 x 32	63	630 x 500 x 63		
40	315 x 160 x 40	2900.6363.32	630 x 630 x 32		
50	315 x 160 x 50	40	630 x 630 x 40		
2900.3120.32	315 x 200 x 32	50	630 x 630 x 50		
40	315 x 200 x 40	63	630 x 630 x 63		
50	315 x 200 x 50	2900.7140.32	710 x 400 x 32		
2900.3125.32	315 x 250 x 32	40	710 x 400 x 40		
40	315 x 250 x 40	50	710 x 400 x 50		
50	315 x 250 x 50	63	710 x 400 x 63		
2900.3131.32	315 x 315 x 32	2900.7150.32	710 x 500 x 32		
40	315 x 315 x 40	40	710 x 500 x 40		
50	315 x 315 x 50	50	710 x 500 x 50		
2900.4020.32	400 x 200 x 32	63	710 x 500 x 63		
40	400 x 200 x 40	2900.7163.32	710 x 630 x 32		
50	400 x 200 x 50	40	710 x 630 x 40		

FIBRO

2910.

Placas de aleación de aluminio ~ISO 6753-1

2910.

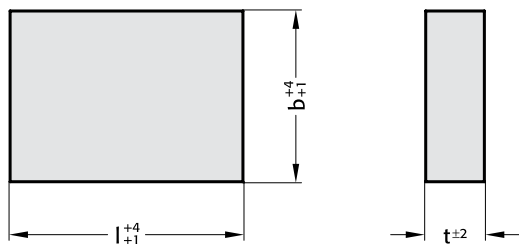

Ejecución: 2910. 0
 Contornos exteriores serrados
 Superficies planas de grosor rectificadas

Placas de medidas desde 500 x 500 mm se suministran con rosca para cáncamo.

2910.

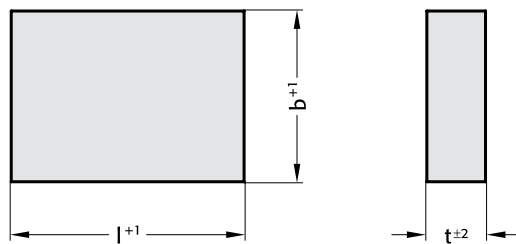

Ejecución: 2910. . . .2
 Dos caras del ángulo fresadas
 Superficies planas de grosor rectificadas

Placas de medidas desde 500 x 500 mm se suministran con rosca para cáncamo.

2910.

Código placa aleac. aluminio	Eje-cución l x b x t	Código placa aleac. aluminio	Eje-cución l x b x t	Código placa aleac. aluminio	Eje-cución l x b x t
2910.1608.25.	160 x 80 x 25	2910.4025.32.	400 x 250 x 32	50.	710 x 630 x 50
32.	160 x 80 x 32	40.	400 x 250 x 40	63.	710 x 630 x 63
2910.1610.25.	160 x 100 x 25	50.	400 x 250 x 50	2910.8040.32.	800 x 400 x 32
32.	160 x 100 x 32	2910.4031.32.	400 x 315 x 32	40.	800 x 400 x 40
2910.1612.25.	160 x 125 x 25	40.	400 x 315 x 40	50.	800 x 400 x 50
32.	160 x 125 x 32	50.	400 x 315 x 50	63.	800 x 400 x 63
2910.1616.25.	160 x 160 x 25	2910.4040.32.	400 x 400 x 32	2910.8050.32.	800 x 500 x 32
32.	160 x 160 x 32	40.	400 x 400 x 40	40.	800 x 500 x 40
2910.2010.25.	200 x 100 x 25	50.	400 x 400 x 50	50.	800 x 500 x 50
32.	200 x 100 x 32	2910.5025.32.	500 x 250 x 32	63.	800 x 500 x 63
40.	200 x 100 x 40	40.	500 x 250 x 40	2910.8063.32.	800 x 630 x 32
2910.2012.25.	200 x 125 x 25	50.	500 x 250 x 50	40.	800 x 630 x 40
32.	200 x 125 x 32	2910.5031.32.	500 x 315 x 32	50.	800 x 630 x 50
40.	200 x 125 x 40	40.	500 x 315 x 40	63.	800 x 630 x 63
2910.2016.25.	200 x 160 x 25	50.	500 x 315 x 50		
32.	200 x 160 x 32	2910.5040.32.	500 x 400 x 32		
40.	200 x 160 x 40	40.	500 x 400 x 40		
2910.2020.25.	200 x 200 x 25	50.	500 x 400 x 50		
32.	200 x 200 x 32	2910.5050.32.	500 x 500 x 32		
40.	200 x 200 x 40	40.	500 x 500 x 40		
2910.2512.25.	250 x 125 x 25	50.	500 x 500 x 50		
32.	250 x 125 x 32	2910.6331.32.	630 x 315 x 32		
40.	250 x 125 x 40	40.	630 x 315 x 40		
2910.2516.25.	250 x 160 x 25	50.	630 x 315 x 50		
32.	250 x 160 x 32	63.	630 x 315 x 63		
40.	250 x 160 x 40	2910.6340.32.	630 x 400 x 32		
2910.2520.25.	250 x 200 x 25	40.	630 x 400 x 40		
32.	250 x 200 x 32	50.	630 x 400 x 50		
40.	250 x 200 x 40	63.	630 x 400 x 63		
2910.2525.25.	250 x 250 x 25	2910.6350.32.	630 x 500 x 32		
32.	250 x 250 x 32	40.	630 x 500 x 40		
40.	250 x 250 x 40	50.	630 x 500 x 50		
2910.3116.32.	315 x 160 x 32	63.	630 x 500 x 63		
40.	315 x 160 x 40	2910.6363.32.	630 x 630 x 32		
50.	315 x 160 x 50	40.	630 x 630 x 40		
2910.3120.32.	315 x 200 x 32	50.	630 x 630 x 50		
40.	315 x 200 x 40	63.	630 x 630 x 63		
50.	315 x 200 x 50	2910.7140.32.	710 x 400 x 32		
2910.3125.32.	315 x 250 x 32	40.	710 x 400 x 40		
40.	315 x 250 x 40	50.	710 x 400 x 50		
50.	315 x 250 x 50	63.	710 x 400 x 63		
2910.3131.32.	315 x 315 x 32	2910.7150.32.	710 x 500 x 32		
40.	315 x 315 x 40	40.	710 x 500 x 40		
50.	315 x 315 x 50	50.	710 x 500 x 50		
2910.4020.32.	400 x 200 x 32	63.	710 x 500 x 63		
40.	400 x 200 x 40	2910.7163.32.	710 x 630 x 32		
50.	400 x 200 x 50	40.	710 x 630 x 40		

Ejemplo de pedido:

Placa de aluminio	=	2910.
l x b = 400 x 400	=	4040.
t = 32	=	32
Ejecución 0	=	0
Código	=	2910.4040.32.0

FIBRO

2010.65. 2010.66.
2010.67. 2010.69.

Portamatrices a columnas standard con placas de aleación de aluminio, símil a DIN 9868/ ISO 11415, sin placas intermedias

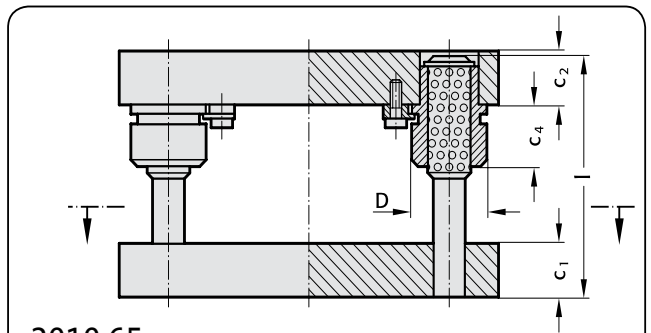

2010.65.

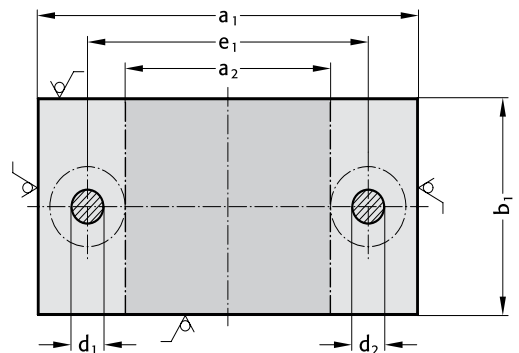

2010.66.

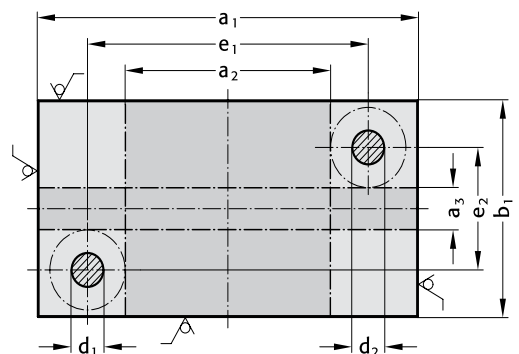

2010.67.

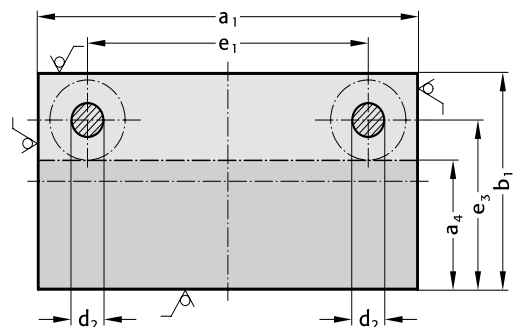

2010.69.

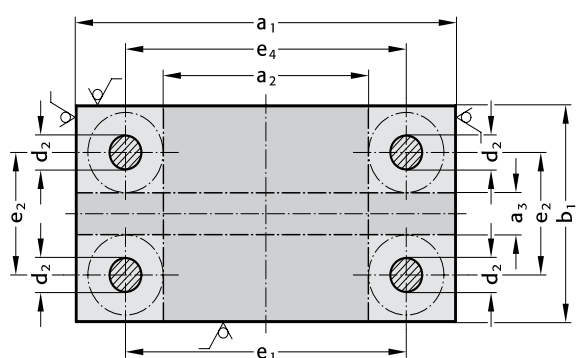

Modelo de guiado standard

Casquillo con valona, sinterizado carbonitrurado

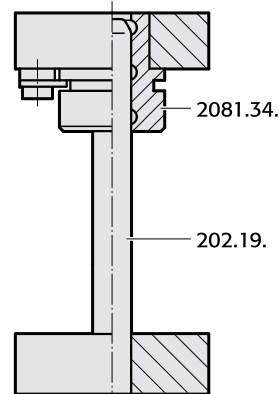

Código parte IV
2010.□□.□□□□□.834.

Casquillo con valona, con guía a bolas

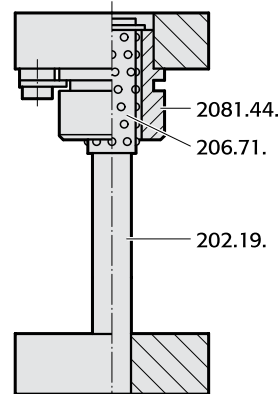

Código parte IV
2010.□□.□□□□□.862.

Descripción:

Los portamatrices de aluminio FIBRO se suministran en ejecución standard con casquillos con valona, sean éstos sinterizados carbonitrurados o guiados a bolas conforme a DIN/ISO. Los casquillos son montados con ajuste suave de gran precisión y sujetos por bridas.

Sobre demanda, todos los portamatrices standard pueden ser suministrados con otros tipos de guía (véanse «combinaciones posibles» en página A 30), o bien en ejecuciones especiales.

Ejemplo de pedido vea página desplegable opuesta.

Portamatrices a columnas standard con placas de aleación de aluminio, similar a DIN 9868/ ISO 11415, con placas intermedias

FIBRO

2010.65. 2010.66.
2010.69.

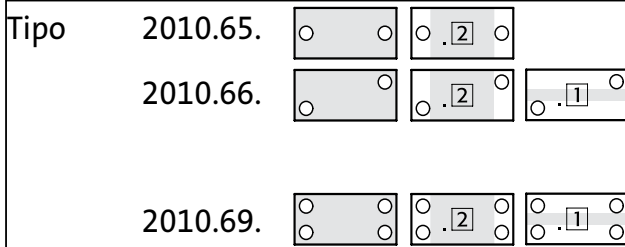

Código		Parte					Medidas	Superf.	Superf.	C ₁	C ₂	C ₃	C ₄	C ₅	d ₁ /d ₂ x l	D	e ₁	e ₂	e ₄
		.I	.II	.III	.IV	.V	ext.	trabajo	trabajo	±2	±2	±2							
Tipo	Tamaño	C.*	Tipo	guía			a ₁ x b ₁	a ₂ x b ₁	a ₁ x a ₃										
2010.	.1608.1.						160 x 80	60 x 80	-	32	32	25	12	12	19/20 x 180	39	100	-	-
	.1610.1.						160 x 100	60 x 100	-	32	32	25	12	12	19/20 x 180	39	100	-	-
	.1612.1.						160 x 125	60 x 125	-	32	32	25	12	12	19/20 x 180	39	100	-	-
	.1616.1.						160 x 160	60 x 160	160 x 60	32	32	25	12	12	19/20 x 180	39	100	100	103
2010.	.2010.1.						200 x 100	70 x 100	-	40	40	25	25	25	24/25 x 200	46	120	-	-
	.2010.2.									40	32								
	.2010.3.									32	40								
	.2010.4.									32	32								
2010.	.2012.1.						200 x 125	70 x 125	-	40	40	25	25	12	24/25 x 200	46	120	-	-
	.2012.2.									40	32								
	.2012.3.									32	40								
	.2012.4.									32	32								
2010.	.2016.1.						200 x 160	70 x 160	-	40	40	25	25	12	24/25 x 200	46	120	-	-
	.2016.2.									40	32								
	.2016.3.									32	40								
	.2016.4.									32	32								
2010.	.2020.1.						200 x 200	70 x 200	200 x 70	40	40	25	25	12	24/25 x 200	46	120	120	123
	.2020.2.									40	32								
	.2020.3.									32	40								
	.2020.4.									32	32								
2010.	.2512.1.						250 x 125	120 x 125	-	40	40	25	25	12	24/25 x 200	46	170	-	-
	.2512.2.									40	32								
	.2512.3.									32	40								
	.2512.4.									32	32								
2010.	.2516.1.						250 x 160	120 x 160	-	40	40	25	25	12	24/25 x 200	46	170	-	-
	.2516.2.									40	32								
	.2516.3.									32	40								
	.2516.4.									32	32								
2010.	.2520.1.						250 x 200	120 x 200	250 x 70	40	40	25	25	12	24/25 x 200	46	170	120	173
	.2520.2.									40	32								
	.2520.3.									32	40								
	.2520.4.									32	32								
2010.	.2525.1.						250 x 250	120 x 250	250 x 120	40	40	25	25	12	24/25 x 200	46	170	170	173
	.2525.2.									40	32								
	.2525.3.									32	40								
	.2525.4.									32	32								
2010.	.3116.1.						315 x 160	165 x 160	-	50	50	32	32	12	30/32 x 224	53	225	-	-
	.3116.2.									50	40								
	.3116.3.									40	50								
	.3116.4.									40	40								
2010.	.3120.1.						315 x 200	165 x 200	315 x 50	50	50	32	32	12	30/32 x 224	53	225	110	228
	.3120.2.									50	40								
	.3120.3.									40	50								
	.3120.4.									40	40								
2010.	.3125.1.						315 x 250	165 x 250	315 x 100	50	50	32	32	12	30/32 x 224	53	225	160	228
	.3125.2.									50	40								
	.3125.3.									40	50								
	.3125.4.									40	40								
2010.	.3131.1.						315 x 315	165 x 315	315 x 165	50	50	32	32	12	30/32 x 224	53	225	225	228
	.3131.2.									50	40								
	.3131.3.									40	50								
	.3131.4.									40	40								
2010.	.4020.1.						400 x 200	250 x 200	400 x 50	50	50	32	32	12	30/32 x 224	53	310	110	313
	.4020.2.									50	40								
	.4020.3.									40	50								
	.4020.4.									40	40								
2010.	.4025.1.						400 x 250	250 x 250	400 x 100	50	50	32	32	12	30/32 x 224	53	310	160	313
	.4025.2.									50	40								
	.4025.3.									40	50								
	.4025.4.									40	40								
2010.	.4031.1.						400 x 315	250 x 315	400 x 165	50	50	32	32	12	30/32 x 224	53	310	225	313
	.4031.2.									50	40								
	.4031.3.									40	50								
	.4031.4.									40	40								

Portamatrices a columnas standard con placas de aleación de aluminio, similar a DIN 9868/ ISO 11415, con placas intermedias

FIBRO

2010.65. 2010.66.
2010.69.

Código		Parte				Medidas ext. $a_1 \times b_1$	Superf. trabajo $a_2 \times b_1$	Superf. trabajo $a_1 \times a_3$	c_1 ± 2	c_2 ± 2	c_3 ± 2	c_4	c_5	$d_1/d_2 \times l$	D	e_1	e_2	e_4
Tipo	Tamaño	III	IV	V														
2010.	4040.1.				400 × 400	250 × 400	400 × 250	50	50	32	32	12	30/32 × 224	53	310	310	313	
	4040.2.							50	40									
	4040.3.							40	50									
	4040.4.							40	40									
2010.	5025.1.				500 × 250	330 × 250	500 × 80	50	50	32	32	15	38/40 × 224	63	400	150	403	
	5025.2.							50	40									
	5025.3.							40	50									
	5025.4.							40	40									
2010.	5031.1.				500 × 315	330 × 315	500 × 145	50	50	32	32	15	38/40 × 224	63	400	215	403	
	5031.2.							50	40									
	5031.3.							40	50									
	5031.4.							40	40									
2010.	5040.1.				500 × 400	330 × 400	500 × 230	50	50	32	32	15	38/40 × 224	63	400	300	403	
	5040.2.							50	40									
	5040.3.							40	50									
	5040.4.							40	40									
2010.	5050.1.				500 × 500	330 × 500	500 × 330	50	50	32	32	15	38/40 × 224	63	400	400	403	
	5050.2.							50	40									
	5050.3.							40	50									
	5050.4.							40	40									
2010.	6331.1.				630 × 315	430 × 315	630 × 115	63	63	40	36	18	48/50 × 280	77	510	195	513	
	6331.2.							63	50				48/50 × 280					
	6331.3.							50	63				48/50 × 250					
	6331.4.							50	50				48/50 × 250					
2010.	6340.1.				630 × 400	430 × 400	630 × 200	63	63	40	36	18	48/50 × 280	77	510	280	513	
	6340.2.							63	50				48/50 × 280					
	6340.3.							50	63				48/50 × 250					
	6340.4.							50	50				48/50 × 250					
2010.	6350.1.				630 × 500	430 × 500	630 × 300	63	63	40	36	18	48/50 × 280	77	510	380	513	
	6350.2.							63	50				48/50 × 280					
	6350.3.							50	63				48/50 × 250					
	6350.4.							50	50				48/50 × 250					
2010.	6363.1.				630 × 630	430 × 630	630 × 430	63	63	40	36	18	48/50 × 280	77	510	510	513	
	6363.2.							63	50				48/50 × 280					
	6363.3.							50	63				48/50 × 250					
	6363.4.							50	50				48/50 × 250					
2010.	7140.1.				710 × 400	510 × 400	710 × 200	63	63	40	36	18	48/50 × 280	77	590	280	593	
	7140.2.							63	50				48/50 × 280					
	7140.3.							50	63				48/50 × 250					
	7140.4.							50	50				48/50 × 250					
2010.	7150.1.				710 × 500	510 × 500	710 × 300	63	63	40	36	18	48/50 × 280	77	590	380	593	
	7150.2.							63	50				48/50 × 280					
	7150.3.							50	63				48/50 × 250					
	7150.4.							50	50				48/50 × 250					
2010.	7163.1.				710 × 630	510 × 630	710 × 430	63	63	40	36	18	48/50 × 280	77	590	510	593	
	7163.2.							63	50				48/50 × 280					
	7163.3.							50	63				48/50 × 250					
	7163.4.							50	50				48/50 × 250					
2010.	8040.1.				800 × 400	600 × 400	800 × 200	63	63	40	36	18	48/50 × 280	77	680	280	683	
	8040.2.							63	50				48/50 × 280					
	8040.3.							50	63				48/50 × 250					
	8040.4.							50	50				48/50 × 250					
2010.	8050.1.				800 × 500	600 × 500	800 × 300	63	63	40	36	18	48/50 × 280	77	680	380	683	
	8050.2.							63	50				48/50 × 280					
	8050.3.							50	63				48/50 × 250					
	8050.4.							50	50				48/50 × 250					
2010.	8063.1.				800 × 630	600 × 630	800 × 430	63	63	40	36	18	48/50 × 280	77	680	510	683	
	8063.2.							63	50				48/50 × 280					
	8063.3.							50	63				48/50 × 250					
	8063.4.							50	50				48/50 × 250					



*C. = Combinación de espesores de placa

Ejemplo de pedido:

Portamatrices modelo = 2010.65.
 Tamaño = 400x250 = 4025.
 Emparejamiento, $c_1 = 50, c_2 = 50$ = 1.
 Tipo de guía – casquillo sinterizado, con valona = 835.
 Superf. trabajo 2 = 2
 Código = 2010.65.4025.1.835.2

Nota:

La disposición de las bridas depende de la posición de la superficie de trabajo, que debe especificarse en la sección V del código de pedido, por ejemplo

2010.69.2520.4.865.1 
 .2 

FIBRO

2010.65. 2010.66.
2010.67. 2010.69.

Portamatrices a columnas standard con placas de aleación de aluminio, similar a DIN 9868/ ISO 11415, sin placas intermedias

Tipo	Código					Medidas ext. $a_1 \times b_1$	Superf. trabajo $a_2 \times b_1$	Superf. trabajo $a_1 \times a_3$	Superf. trabajo $a_1 \times a_4$	c_1 ± 2	c_2 ± 2	c_4 S	c_4 K	$d_1/d_2 \times l$	D	e_1	e_2	e_3	e_4	
	Parte .I	.II	.III	.IV	.V															
2010.65.																				
2010.66.																				
2010.67.																				
2010.69.																				
2010.	.1608.1.					160 × 80	60 × 80	-	-	32	32	20	36	19/20 × 160	39	100	-	-	-	
	.1610.1.					160 × 100	60 × 100	-	160 × 50	32	32	20	36	19/20 × 160	39	100	-	70	-	
	.1612.1.					160 × 125	60 × 125	-	160 × 75	32	32	20	36	19/20 × 160	39	100	-	95	-	
	.1616.1.					160 × 160	60 × 160	160 × 60	160 × 110	32	32	20	36	19/20 × 160	39	100	100	130	103	
2010.	.2010.1.					200 × 100	70 × 100	-	-	40	40	36	56	24/25 × 180	46	120	-	-	-	
	.2010.2.									40	32									
	.2010.3.									32	40									
	.2010.4.									32	32									
2010.	.2012.1.					200 × 125	70 × 125	-	200 × 60	40	40	36	56	24/25 × 180	46	120	-	85	-	
	.2012.2.									40	32									
	.2012.3.									32	40									
	.2012.4.									32	32									
2010.	.2016.1.					200 × 160	70 × 160	-	200 × 95	40	40	36	56	24/25 × 180	46	120	-	120	-	
	.2016.2.									40	32									
	.2016.3.									32	40									
	.2016.4.									32	32									
2010.	.2020.1.					200 × 200	70 × 200	200 × 70	200 × 135	40	40	36	56	24/25 × 180	46	120	120	160	123	
	.2020.2.									40	32									
	.2020.3.									32	40									
	.2020.4.									32	32									
2010.	.2512.1.					250 × 125	120 × 125	-	250 × 60	40	40	36	56	24/25 × 180	46	170	-	85	-	
	.2512.2.									40	32									
	.2512.3.									32	40									
	.2512.4.									32	32									
2010.	.2516.1.					250 × 160	120 × 160	-	250 × 95	40	40	36	56	24/25 × 180	46	170	-	120	-	
	.2516.2.									40	32									
	.2516.3.									32	40									
	.2516.4.									32	32									
2010.	.2520.1.					250 × 200	120 × 200	250 × 70	250 × 135	40	40	36	56	24/25 × 180	46	170	120	160	173	
	.2520.2.									40	32									
	.2520.3.									32	40									
	.2520.4.									32	32									
2010.	.2525.1.					250 × 250	120 × 250	250 × 120	250 × 185	40	40	36	56	24/25 × 180	46	170	170	210	173	
	.2525.2.									40	32									
	.2525.3.									32	40									
	.2525.4.									32	32									
2010.	.3116.1.					315 × 160	165 × 160	-	315 × 85	50	50	45	63	30/32 × 200	53	225	-	115	-	
	.3116.2.									50	40									
	.3116.3.									40	50									
	.3116.4.									40	40									
2010.	.3120.1.					315 × 200	165 × 200	315 × 50	315 × 125	50	50	45	63	30/32 × 200	53	225	110	155	228	
	.3120.2.									50	40									
	.3120.3.									40	50									
	.3120.4.									40	40									
2010.	.3125.1.					315 × 250	165 × 250	315 × 100	315 × 175	50	50	45	63	30/32 × 200	53	225	160	205	228	
	.3125.2.									50	40									
	.3125.3.									40	50									
	.3125.4.									40	40									
2010.	.3131.1.					315 × 315	165 × 315	315 × 165	315 × 240	50	50	45	63	30/32 × 200	53	225	225	270	228	
	.3131.2.									50	40									
	.3131.3.									40	50									
	.3131.4.									40	40									
2010.	.4020.1.					400 × 200	250 × 200	400 × 50	400 × 125	50	50	45	63	30/32 × 200	53	310	110	155	313	
	.4020.2.									50	40									
	.4020.3.									40	50									
	.4020.4.									40	40									
2010.	.4025.1.					400 × 250	250 × 250	400 × 100	400 × 175	50	50	45	63	30/32 × 200	53	310	160	205	313	
	.4025.2.									50	40									
	.4025.3.									40	50									
	.4025.4.									40	40									
2010.	.4031.1.					400 × 315	250 × 315	400 × 165	400 × 240	50	50	45	63	30/32 × 200	53	310	225	270	313	
	.4031.2.									50	40									
	.4031.3.									40	50									
	.4031.4.									40	40									

FIBRO

2010.65. 2010.66.
2010.67. 2010.69.

Portamatrices a columnas standard con placas de aleación de aluminio, similar a DIN 9868/ ISO 11415, sin placas intermedias

Código Parte	.I	.II	.III	.IV	.V	Medidas ext. a ₁ x b ₁	Superf. trabajo a ₂ x b ₂	Superf. trabajo a ₁ x a ₃	Superf. trabajo a ₁ x a ₄	c ₁ ±2	c ₂ ±2	C ₄ S	C ₄ K	d ₁ /d ₂ x l	D	e ₁	e ₂	e ₃	e ₄
2010.		.4040.1.				400 x 400	250 x 400	400 x 250	400 x 325	50	50	45	63	30/32 x 200	53	310	310	355	313
		.4040.2.								50	40								
		.4040.3.								40	50								
		.4040.4.								40	40								
2010.		.5025.1.				500 x 250	330 x 250	500 x 80	500 x 165	50	50	45	71	38/40 x 200	63	400	150	200	403
		.5025.2.								50	40								
		.5025.3.								40	50								
		.5025.4.								40	40								
2010.		.5031.1.				500 x 315	330 x 315	500 x 145	500 x 230	50	50	45	71	38/40 x 200	63	400	215	265	403
		.5031.2.								50	40								
		.5031.3.								40	50								
		.5031.4.								40	40								
2010.		.5040.1.				500 x 400	330 x 400	500 x 230	500 x 315	50	50	45	71	38/40 x 200	63	400	300	350	403
		.5040.2.								50	40								
		.5040.3.								40	50								
		.5040.4.								40	40								
2010.		.5050.1.				500 x 500	330 x 500	500 x 330	500 x 415	50	50	45	71	38/40 x 200	63	400	400	450	403
		.5050.2.								50	40								
		.5050.3.								40	50								
		.5050.4.								40	40								
2010.		.6331.1.				630 x 315	430 x 315	630 x 115	630 x 215	63	63	50	80	48/50 x 250	77	510	195	255	513
		.6331.2.								63	50			48/50 x 250					
		.6331.3.								50	63			48/50 x 224					
		.6331.4.								50	50			48/50 x 224					
2010.		.6340.1.				630 x 400	430 x 400	630 x 200	630 x 300	63	63	50	80	48/50 x 250	77	510	280	340	513
		.6340.2.								63	50			48/50 x 250					
		.6340.3.								50	63			48/50 x 224					
		.6340.4.								50	50			48/50 x 224					
2010.		.6350.1.				630 x 500	430 x 500	630 x 300	630 x 400	63	63	50	80	48/50 x 250	77	510	380	440	513
		.6350.2.								63	50			48/50 x 250					
		.6350.3.								50	63			48/50 x 224					
		.6350.4.								50	50			48/50 x 224					
2010.		.6363.1.				630 x 630	430 x 630	630 x 430	630 x 530	63	63	50	80	48/50 x 250	77	510	510	570	513
		.6363.2.								63	50			48/50 x 250					
		.6363.3.								50	63			48/50 x 224					
		.6363.4.								50	50			48/50 x 224					
2010.		.7140.1.				710 x 400	510 x 400	710 x 200	710 x 300	63	63	50	80	48/50 x 250	77	590	280	340	593
		.7140.2.								63	50			48/50 x 250					
		.7140.3.								50	63			48/50 x 224					
		.7140.4.								50	50			48/50 x 224					
2010.		.7150.1.				710 x 500	510 x 500	710 x 300	710 x 400	63	63	50	80	48/50 x 250	77	590	380	440	593
		.7150.2.								63	50			48/50 x 250					
		.7150.3.								50	63			48/50 x 224					
		.7150.4.								50	50			48/50 x 224					
2010.		.7163.1.				710 x 630	510 x 630	710 x 430	710 x 530	63	63	50	80	48/50 x 250	77	590	510	570	593
		.7163.2.								63	50			48/50 x 250					
		.7163.3.								50	63			48/50 x 224					
		.7163.4.								50	50			48/50 x 224					
2010.		.8040.1.				800 x 400	600 x 400	800 x 200	800 x 300	63	63	50	80	48/50 x 250	77	680	280	340	683
		.8040.2.								63	50			48/50 x 250					
		.8040.3.								50	63			48/50 x 224					
		.8040.4.								50	50			48/50 x 224					
2010.		.8050.1.				800 x 500	600 x 500	800 x 300	800 x 400	63	63	50	80	48/50 x 250	77	680	380	440	683
		.8050.2.								63	50			48/50 x 250					
		.8050.3.								50	63			48/50 x 224					
		.8050.4.								50	50			48/50 x 224					
2010.		.8063.1.				800 x 630	600 x 630	800 x 430	800 x 530	63	63	50	80	48/50 x 250	77	680	510	570	683
		.8063.2.								63	50			48/50 x 250					
		.8063.3.								50	63			48/50 x 224					
		.8063.4.								50	50			48/50 x 224					



*C. = Combinación de espesores de placa

Ejemplo de pedido:

Portamatrices modelo = 2010.65.
 Tamaño = 400x250 = 4025.
 Emparejamiento c₁ = 50, c₂ = 50 = 1.
 Tipo de guía – casquillo sinterizado, con valona = 834.
 Superf. trabajo 2 = 2
 Código = 2010.65.4025.1.834.2

Nota:

La disposición de las bridas depende de la posición de la superficie de trabajo, que debe especificarse en la sección V del código de pedido, por ejemplo

2010.69.2520.4.862.1 
 .2 

Portamatrices a columnas standard con placas de aleación de aluminio, similar a DIN 9868/ ISO 11415, con placas intermedias

FIBRO

2010.65. 2010.66.
2010.69.

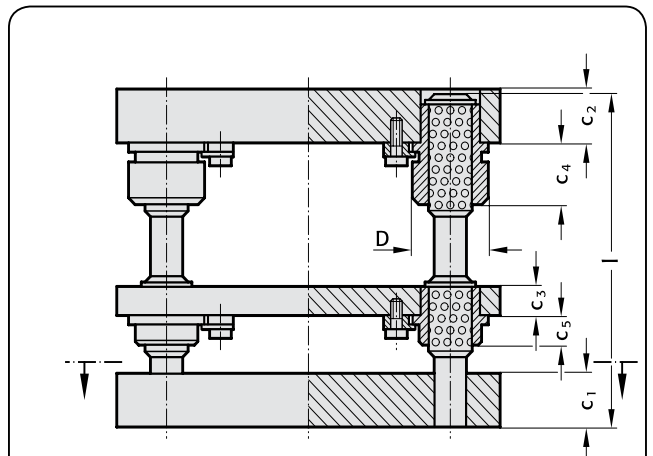

2010.65.

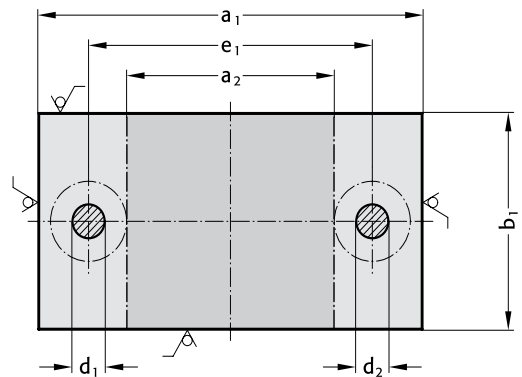

2010.66.

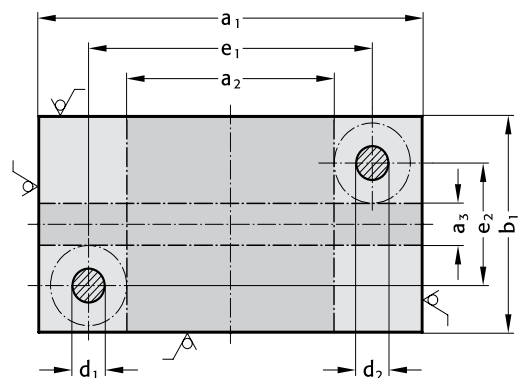

2010.69.

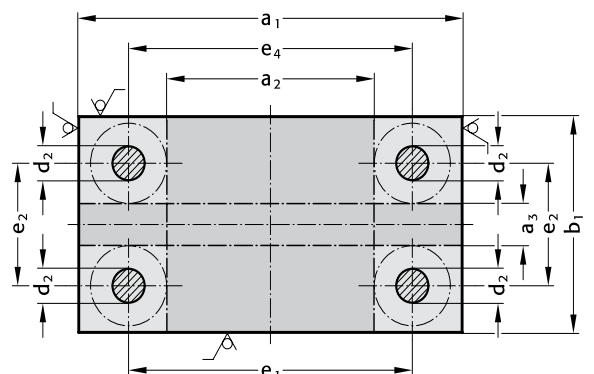

Modelo de guiado standard

Casquillo con valona sinterizado, carbonitrurado

Casquillo con valona sinterizado, con guía a bolas

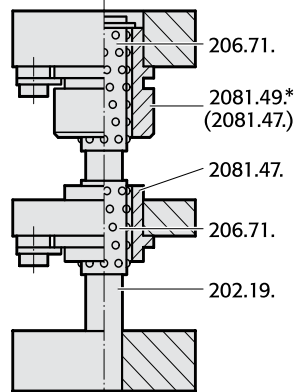
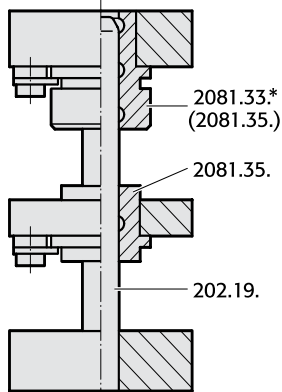

Código parte IV
2010.□□.□□□□.□.835.

Código parte IV
2010.□□.□□□□.□.865.

* Hasta tamaño 2010.□□.1616. = 2081.35./2081.47.

Descripción:

Los portamatrices de aluminio FIBRO con placas intermedias se suministran en ejecución standard con casquillos con valona, sean éstos sinterizados carbonitrurados o guiados a bolas. Los casquillos son montados con ajuste suave de gran precisión y sujetos por bridas.

Sobre demanda, todos los portamatrices standard pueden ser suministrados con otros tipos de guía (véanse «combinaciones posibles» en página A30), o bien en ejecuciones especiales.

Ejemplo de pedido vea página desplegable opuesta.

Portamatrices

Pequeñas prensas a columnas con y sin placas intermedias

FIBRO
2011.45.
2011.49.

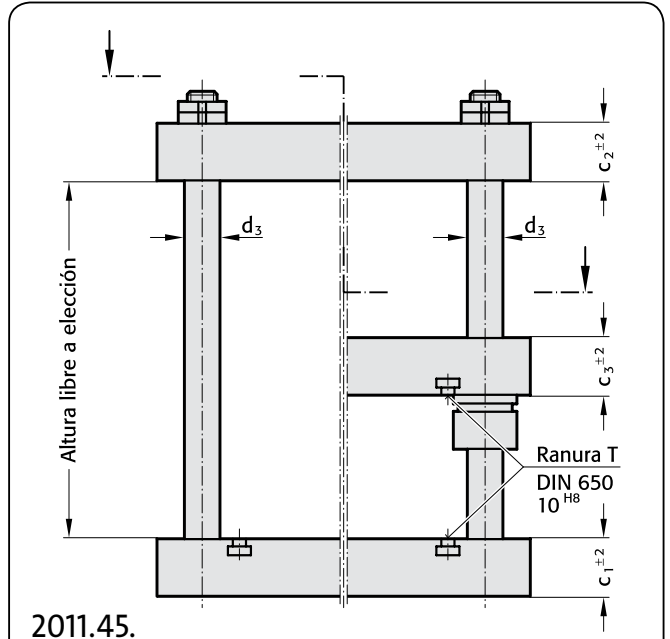

2011.49.

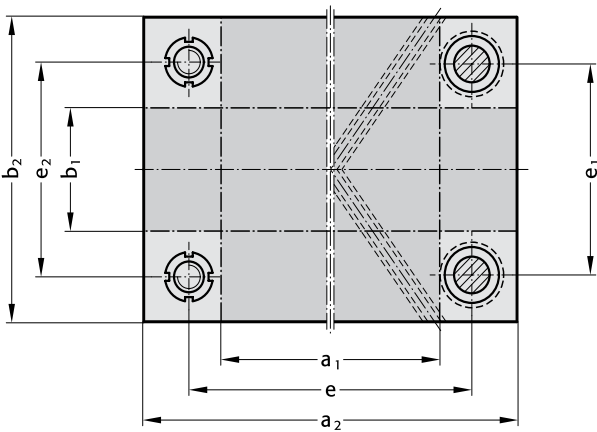

2011.45.

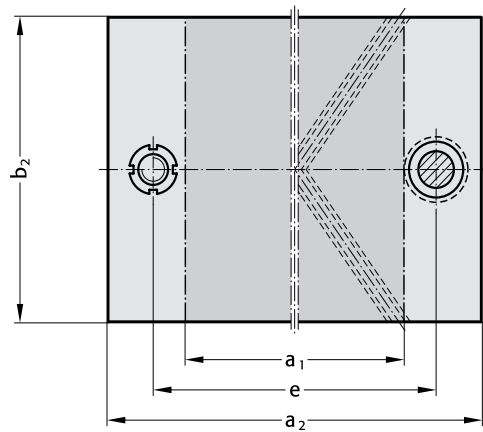

Sistema de códigos de pedido:

2011.4□□4031. □□□. □□□.1

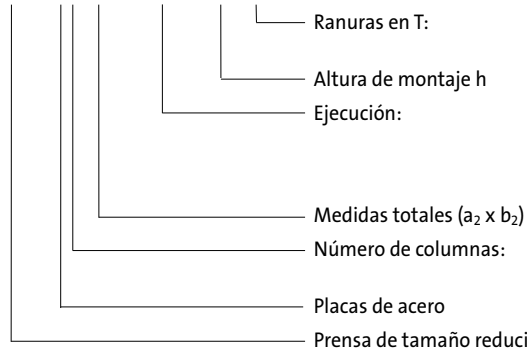

Para elementos de acoplamiento y sujeción para la unión del cilindro con el útil consulte la página A 44

.0 = sin
.1 = en la base y en la placa intermedia

000. = sin placa de guía
001. = sin placa de guía – elementos de elevación sin templar
831. = Placa de guía con guiado liso
862. = Placa de guía con guía a bolas
40: a₂ = 400 mm; 31: b₂ = 315 mm
5. = dos columnas de guía
9. = cuatro columnas de guía

2011.

Código		Superficie de trabajo a ₁ x b ₂	Superficie de trabajo a ₂ x b ₁	Fuerza de prensado admisible en kN	a ₂	b ₂	c ₁	c ₂	c ₃	d ₃	e	e ₁	e ₂
					200	200	32	32	32	25	132	132	129
2011.	.2020.	86 x 200	200 x 65	20	200	200	32	32	32	25	132	132	129
	.2520.	136 x 200	250 x 64		250	200	32	32	32	25	182	132	129
	.2525.	120 x 250	250 x 100	40	250	250	40	40	40	32	174	174	171
	.3125.	185 x 250	315 x 100		315	250	40	40	40	32	239	174	171
	.3131.	185 x 315	315 x 165		315	315	40	40	40	32	239	239	236
	.4031.	270 x 315	400 x 165	80	400	315	50	50	50	32	324	239	236
	.4040.	270 x 400	400 x 250		400	400	50	50	50	32	324	324	321

FIBRO

201.145.
201.149.

Portamatrices / Pequeñas prensas a columnas.
Con placa intermedia.
Accionamiento manual.

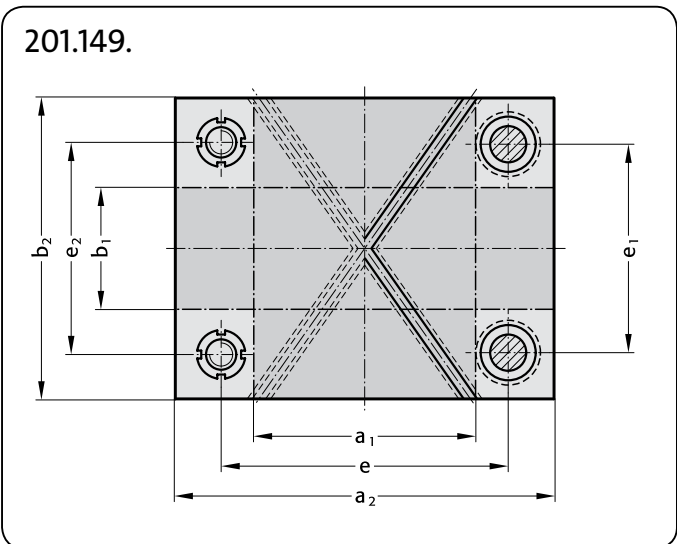
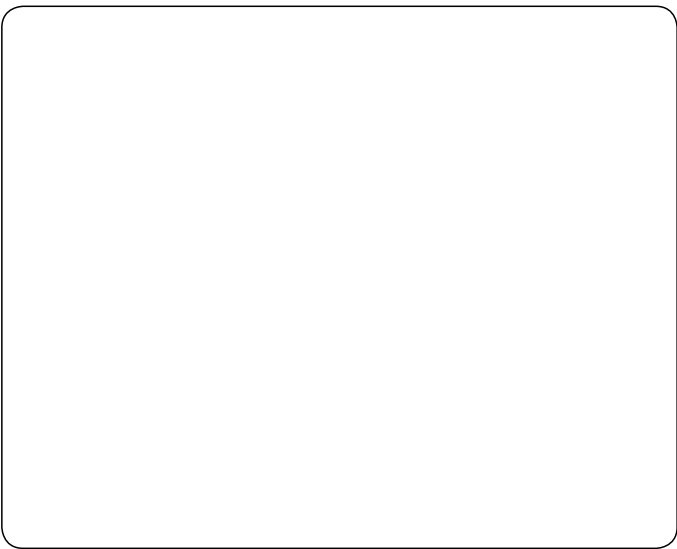
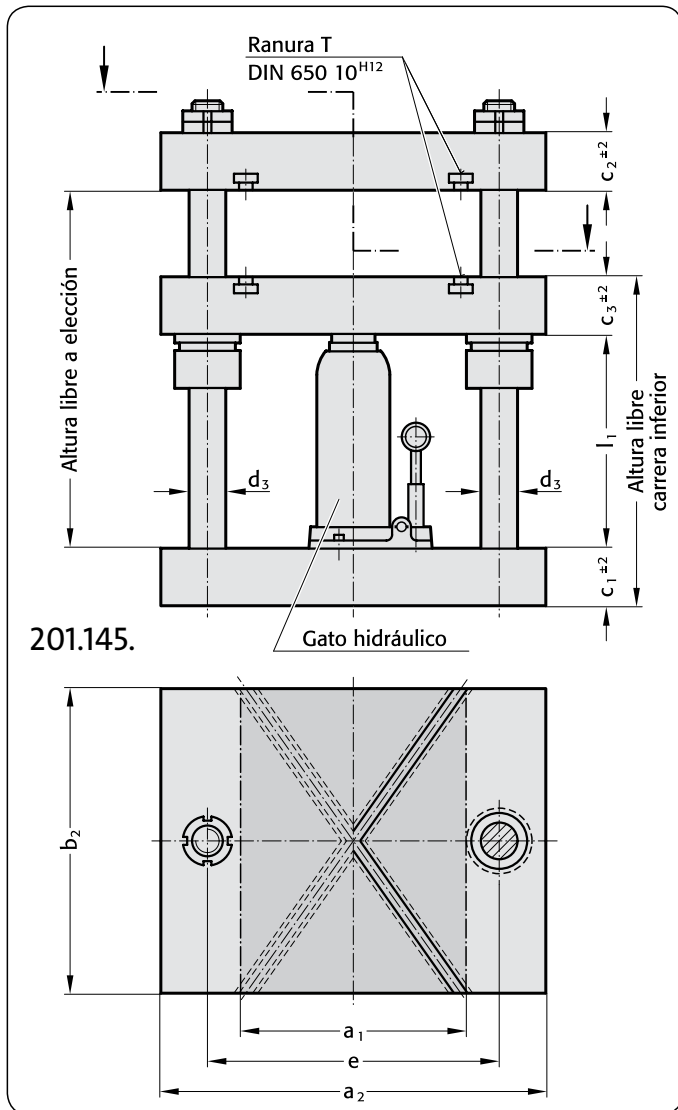

Sistema de códigos de pedido:

201.14 □ .4031. □ □ □ . □ □ □ .1

- Ranuras en T: .0 = sin
.1 = en placa superior y placa intermedia
- Altura de montaje h
- Ejecución: 831 = Placa de guía con casquillos de fricción.
862 = Placa de guía con casquillos a bolas.
- Medidas totales (a₂ x b₂) 40: a₂ = 400 mm; 31: b₂ = 315 mm
- Número de columnas: 5 = dos columnas de guía
9 = cuatro columnas de guía
- Placas de acero
- Prensa de tamaño reducido – Tamaños ISO

Ejecución: Casquillos de guía con valona.
Gato hidráulico..

201.		Superficie de trabajo a ₁ u b ₂	Superficie de trabajo a ₂ u b ₁	Fuerza de prensado admisible en kN	a ₂	b ₂	c ₁	c ₂	c ₃	d ₃	e	e ₁	e ₂	l ₁	Cursa max.
201.	.2020.	86 × 200	200 × 65	20	200	200	32	32	32	25	132	132	129	180	130
	.2520.	136 × 200	250 × 64		250	200	32	32	32	25	182	132	129		
	.2525.	120 × 250	250 × 100	40	250	250	40	40	40	32	174	174	171		
	.3125.	185 × 250	315 × 100		315	250	40	40	40	32	239	174	171	200	130
	.3131.	185 × 315	315 × 165		315	315	40	40	40	32	239	239	236		
	.4031.	270 × 315	400 × 165	80	400	315	50	50	50	32	324	239	236	245	160
	.4040.	270 × 400	400 × 250		400	400	50	50	50	32	324	324	321		

Accesorios para portamatrices
Piezas de conexión (conectores)
Tirantes de acoplamiento

FIBRO

212.16.1.

212.11. 212.15.



212.16.1.

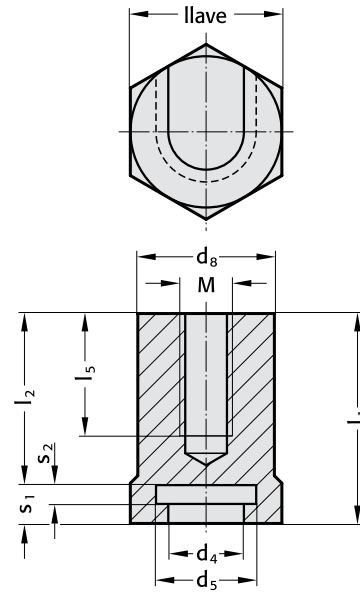

212.16.1. Pieza de conexión (conector)

Código	d ₄	d ₅	d ₈	llave	l ₁	l ₂	l ₅	M	s ₁	s ₂
212.16.1. 026	26	33	45	50	70	57,4		según	12,6	7
033	33	49	60	65	86	67,4	indicación	18,6	10	

212.11.

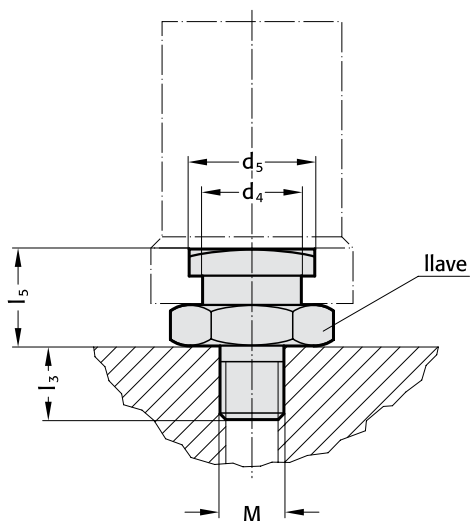

212.15.

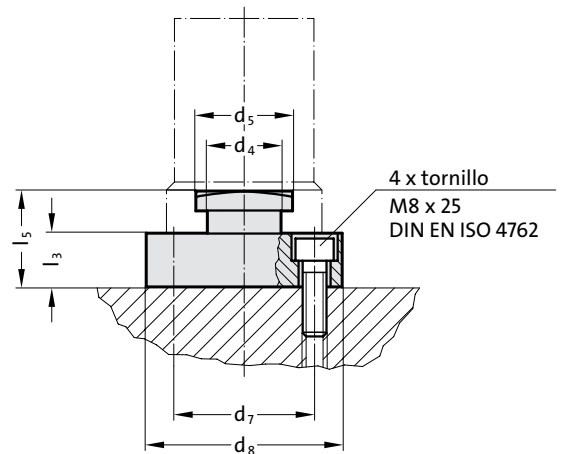

212.11. Tirantes de acoplamiento

Código	M	d ₄	d ₅	l ₃	l ₅	llave
212.11. 016	M16 × 1.5	25	32	18	23	36
030	M30 × 2	32	48	30	43	60

212.15. Tirantes de acoplamiento

Código	d ₄	d ₅	d ₈	d ₇	l ₃	l ₅
212.15. 063	25	32	63	46	18	31
080	32	48	80	63	18	37

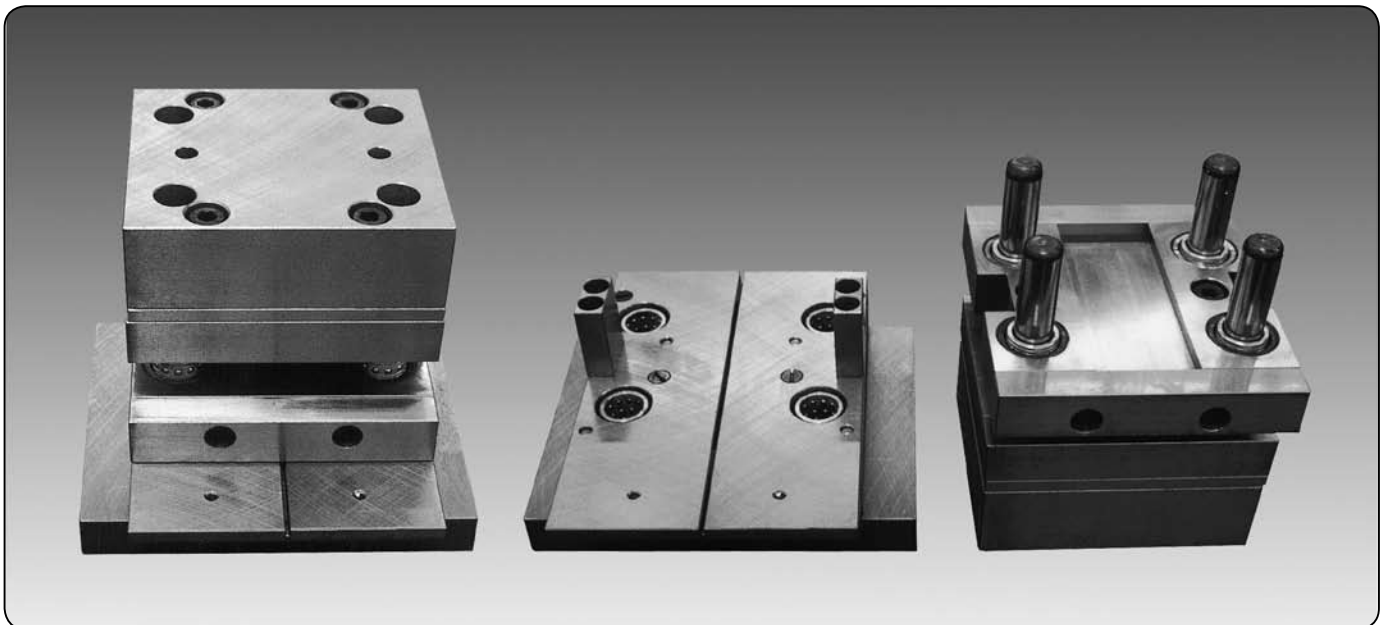
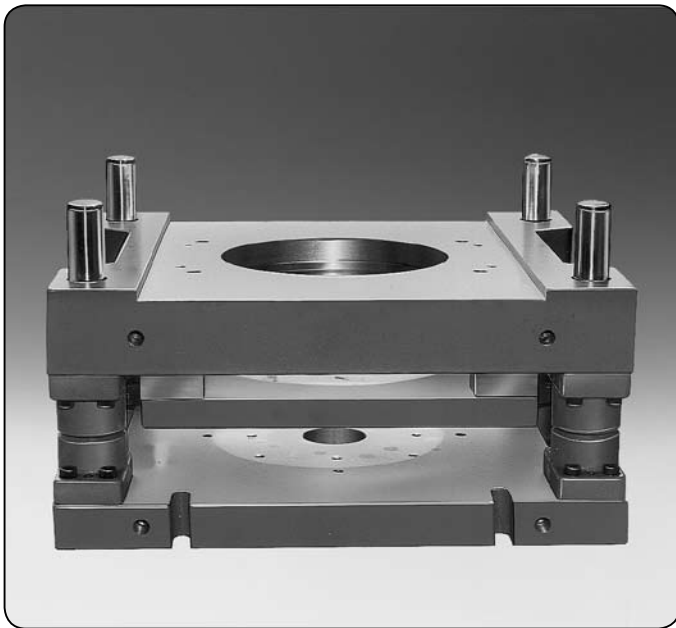
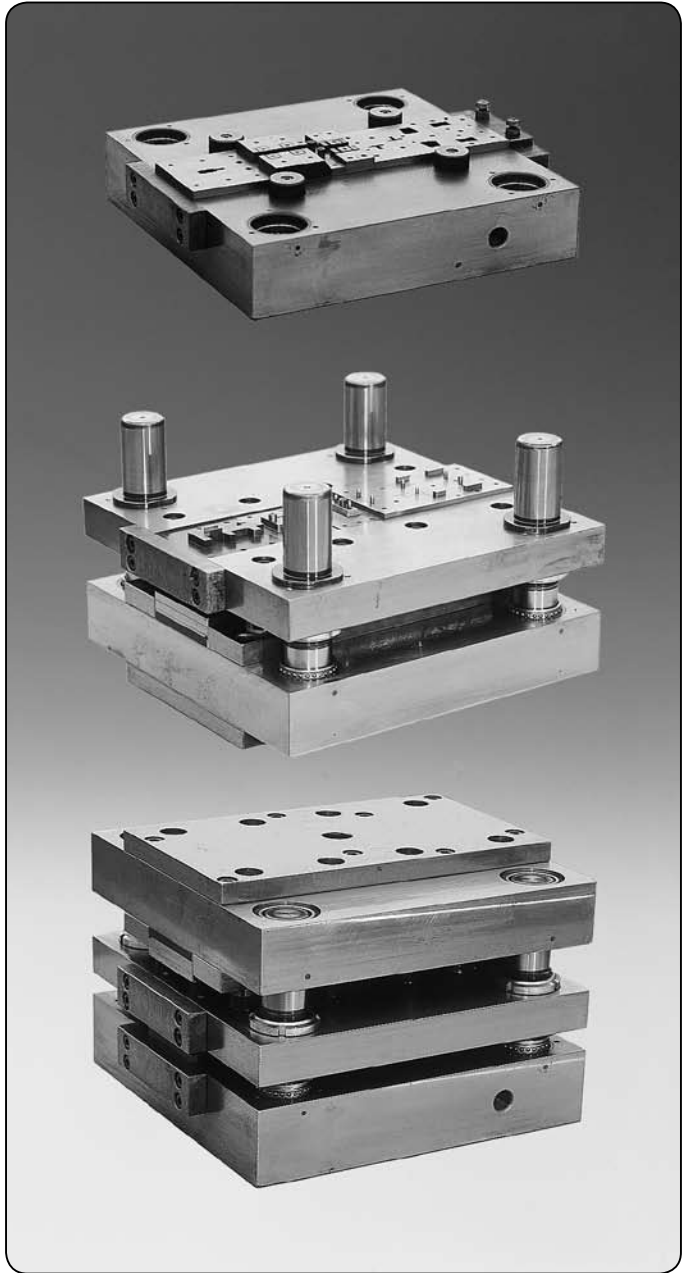

Portamatrices a columnas
con placas de acero especiales,
según plano del cliente

FIBRO

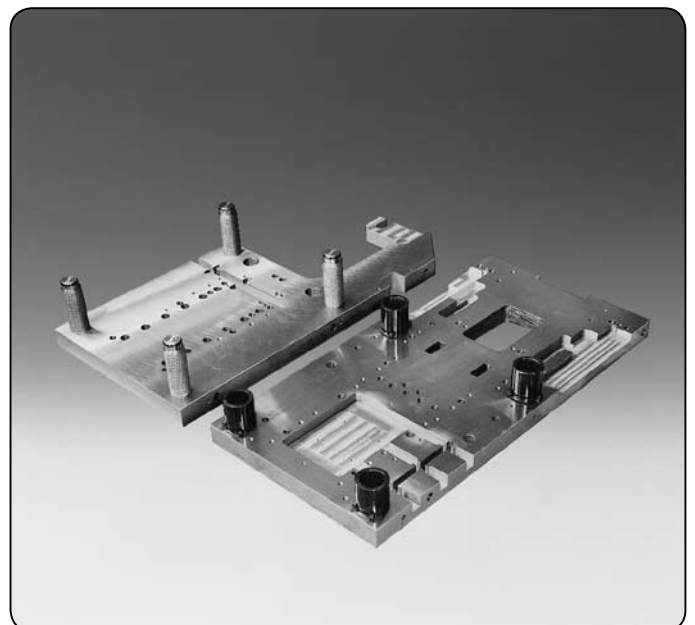

FIBRO

Portamatrices a columnas
con placas de acero especiales,
según plano del cliente

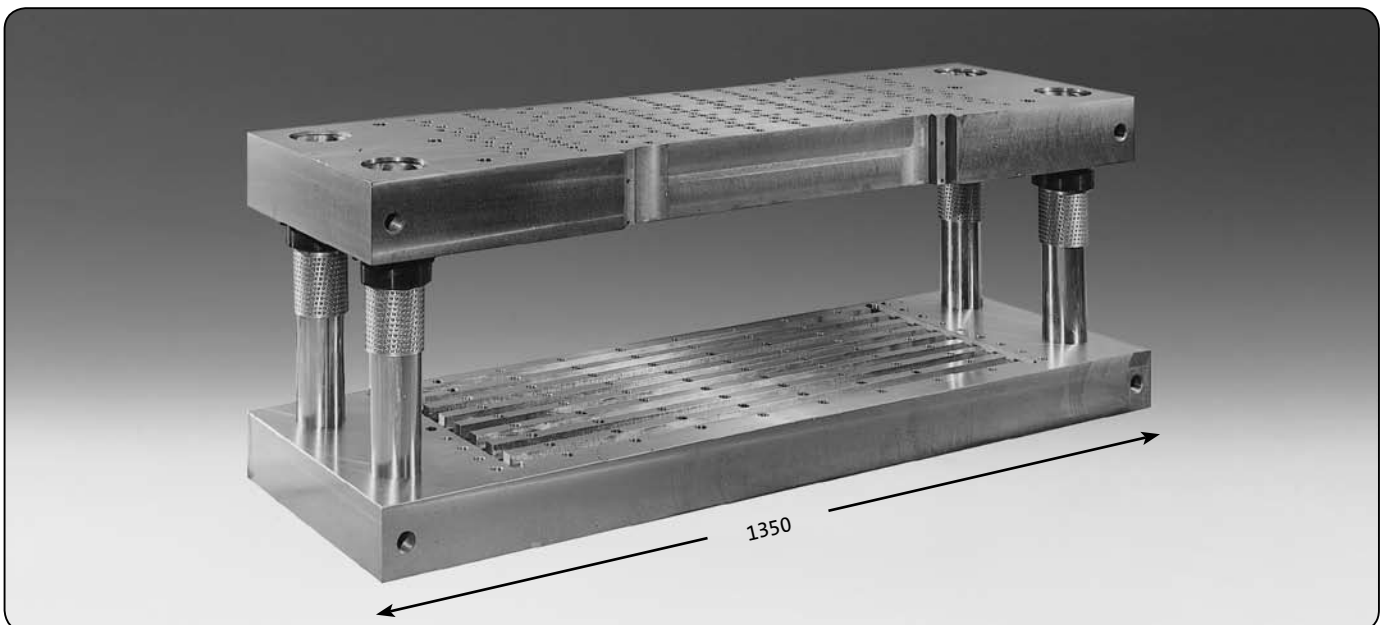
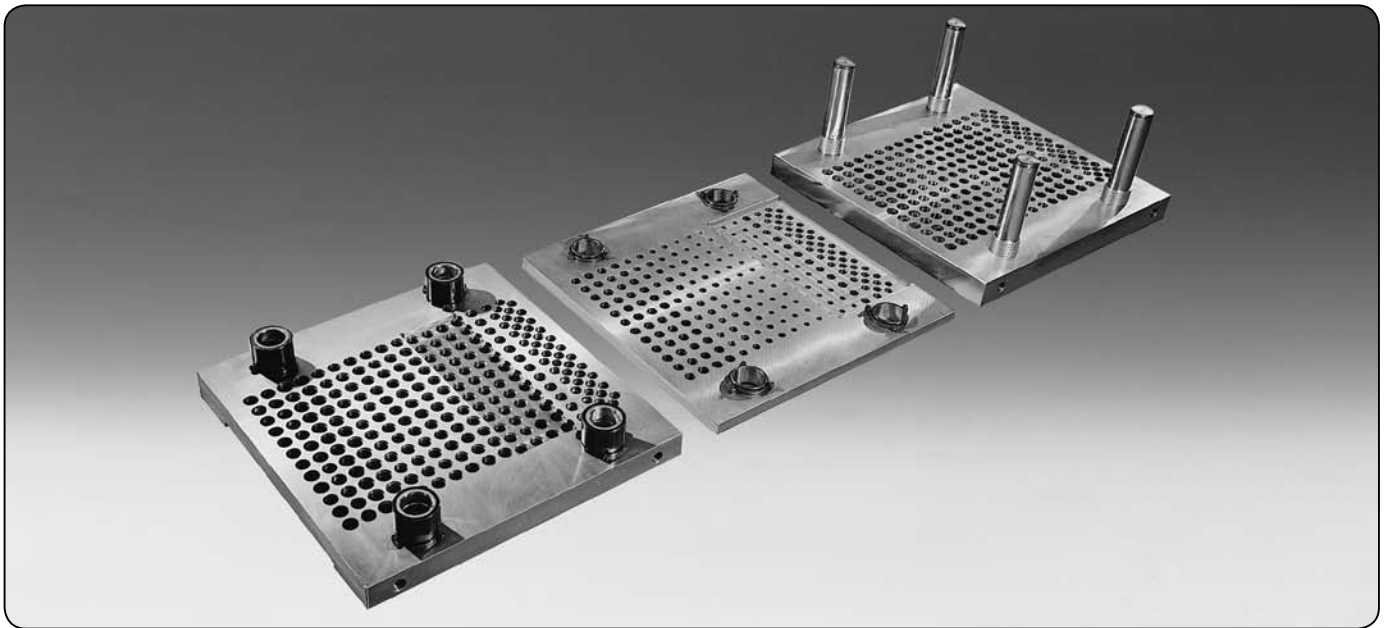
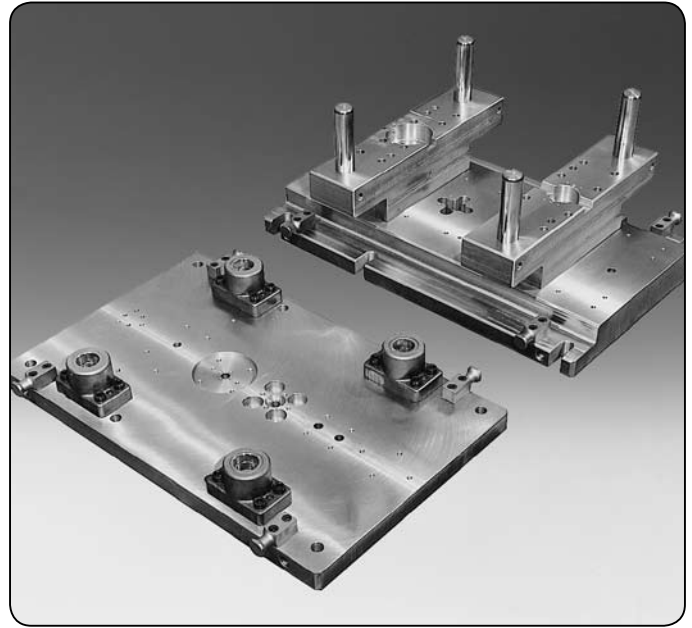
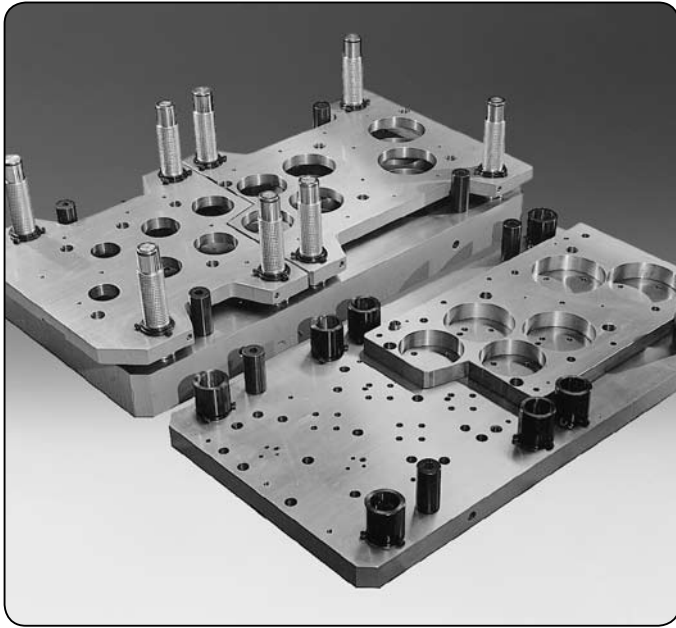

Portamatrices a columnas
con placas de acero especiales,
según plano del cliente

FIBRO

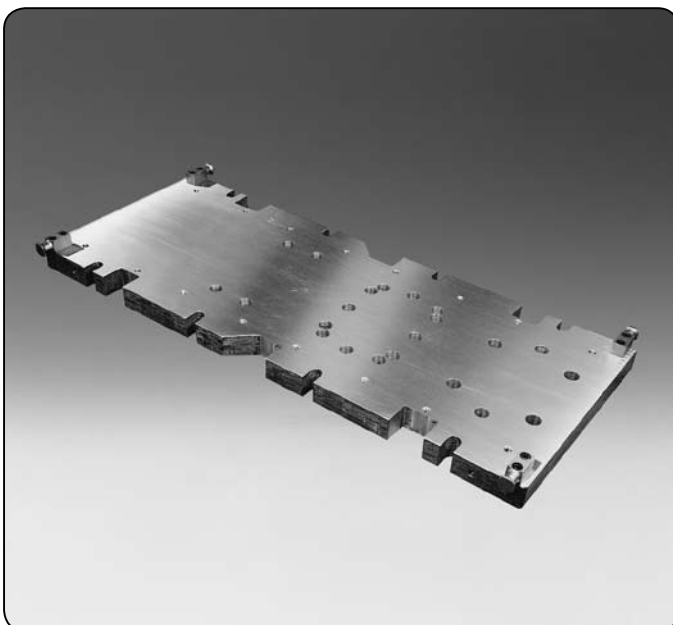
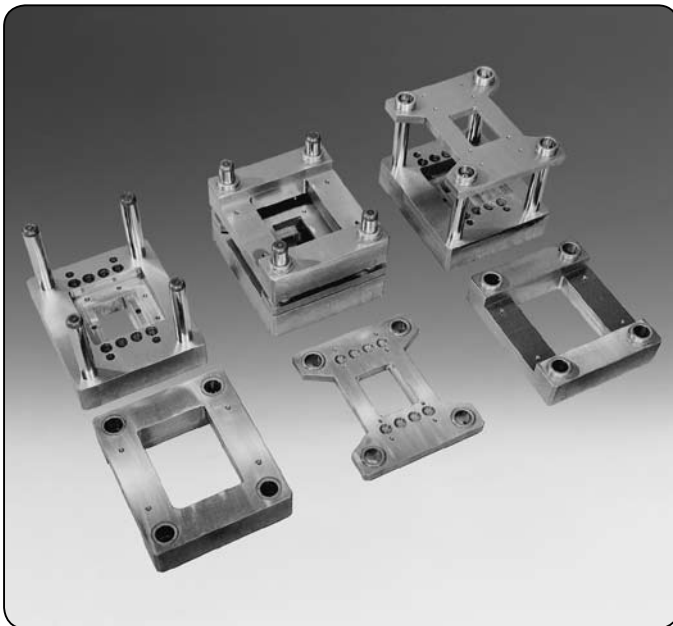
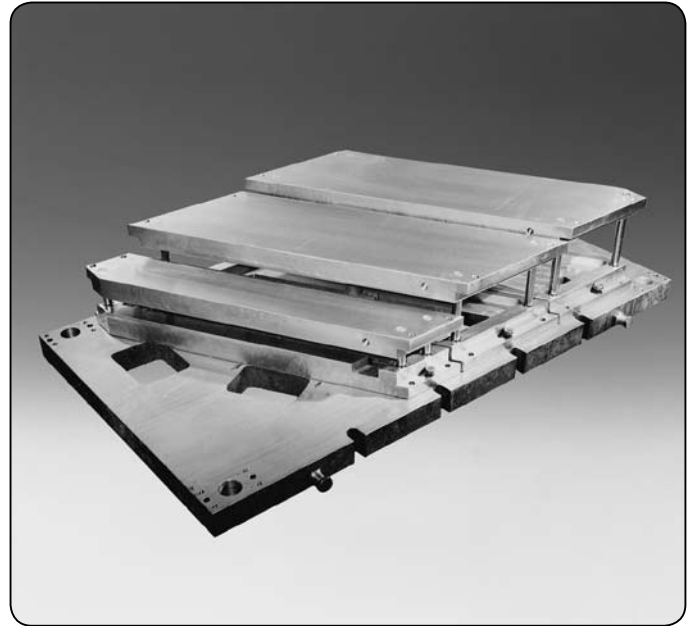
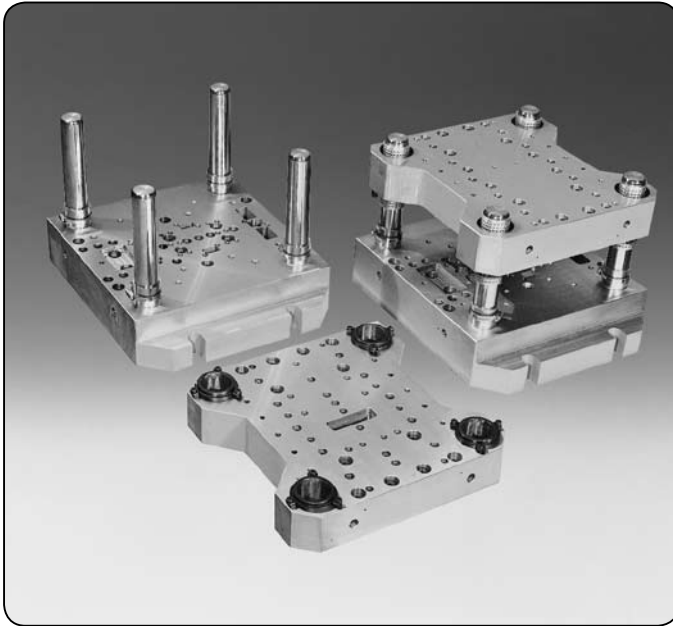



Portamatrices de precisión para útiles combinados progresivos

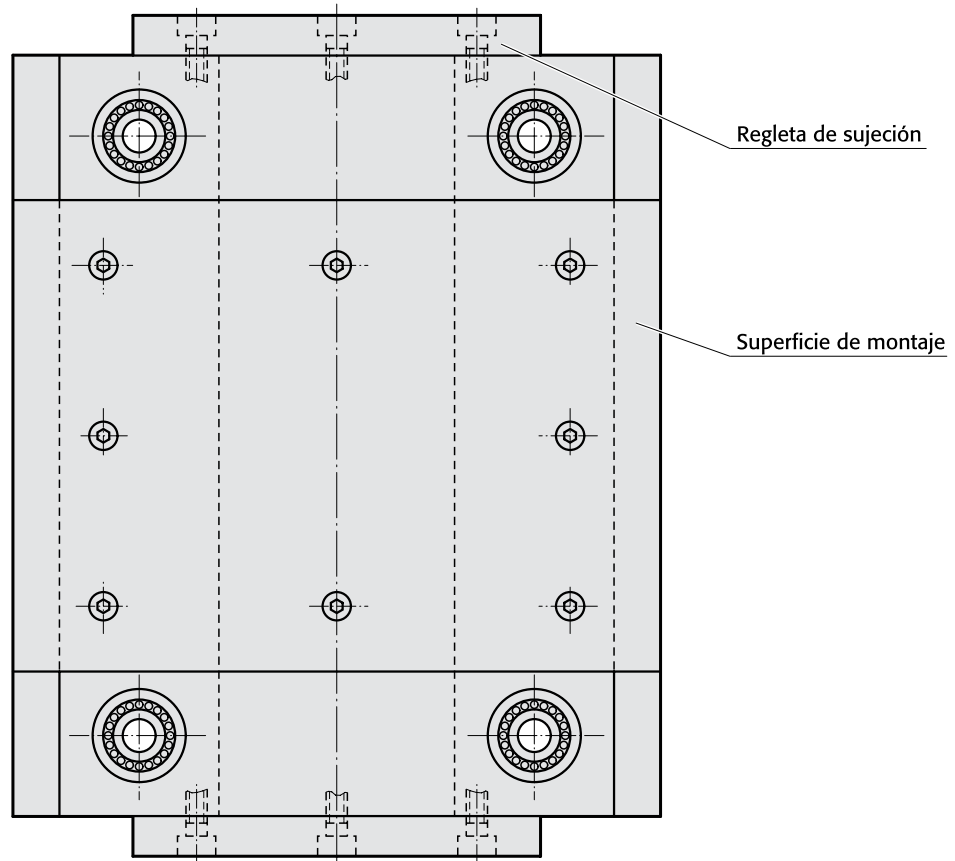
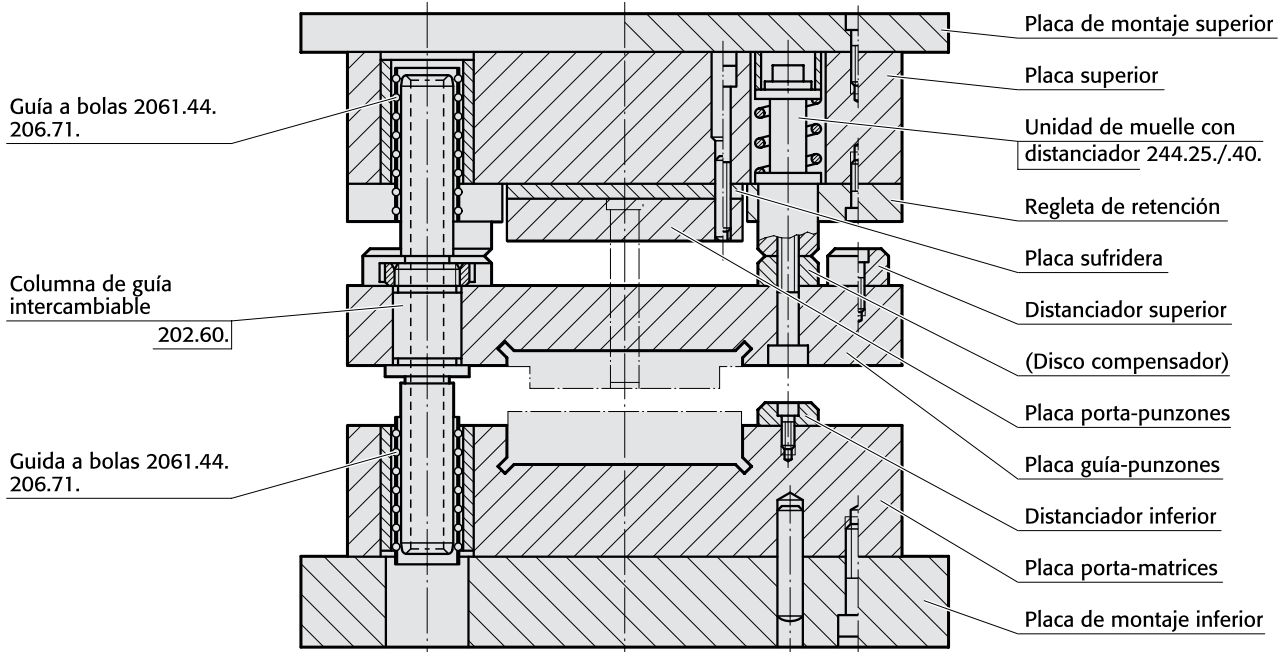

Portamatrices de precisión para útiles combinados progresivos

201.50.

201.50.

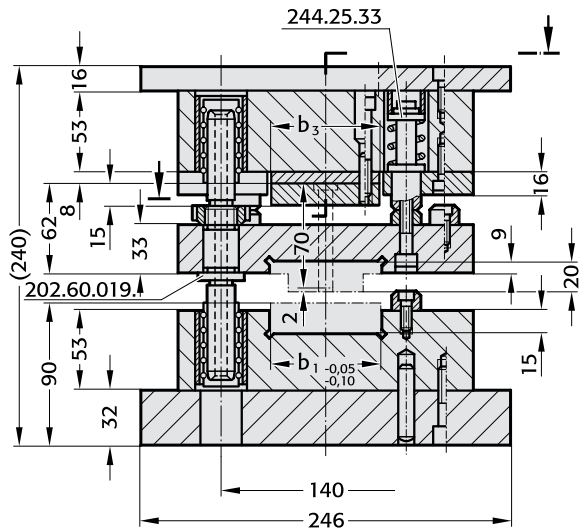

* Para los tamaños 201.50.2520 y 3020, se utilizan columnas de guía 202.60.025.

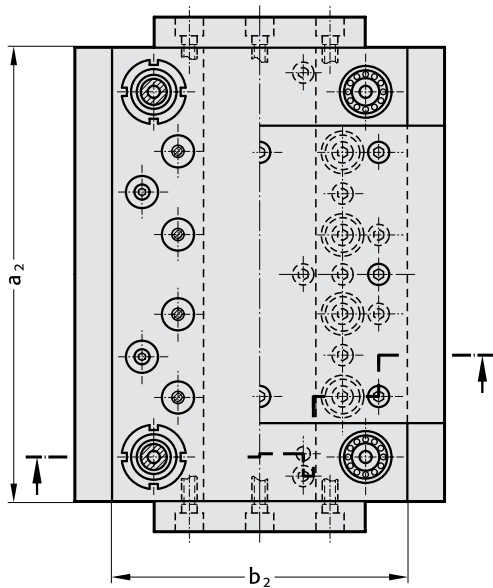

Ejecución

Posibilidad de fijación en la placa superior.

201.50.□□□.□□.□□.1

Con placa de fijación sobresaliente

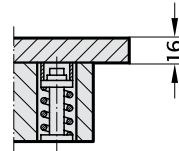

201.50.□□□.□□.□□.2

Con taladro roscado para tirante en la placa de fijación

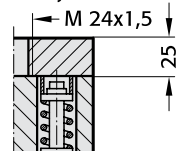

201.50.□□□.□□.□□.3

Con taladro roscado para tirante en la parte superior

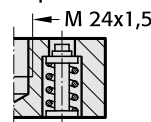

201.50.□□□.□□.□□.4

Con alojamiento de fijación en la parte superior

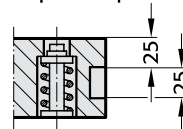

Modo de guiado

Guía a bolas

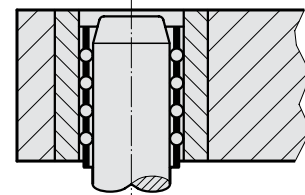

Anchura a rectificar b_1 a determinar por el cliente!

Sobre demanda, facilitaremos para la composición del útil datos 2D-CAD. El usuario ha de dibujar solamente las partes activas del útil.

Por modificación del grueso de la placa de sujeción puede reducirse en caso necesario la altura de la zona de alimentación de la chapa en hasta 3 mm, así como la altura de montaje del útil.

201.50.		Tipo de muelle	Medida exter.	Com. bin. de muelle	Max. compr. de muelle	Carrera con pre-carga	pre-carga del muelle en N	Fuerza R en N
Código mod.	Tamaño b_1	Ejec.	$a_2 \times b_2$	b_1 max. +dist.	b_3		241.□□.25.032	241.□□.25.032
							14 15 16 17	14 15 16 17
201.50.1320.	□□□.□□.□	□□□.□□.□	126 × 196	40 4	40	6,0 6,0 5,0	241 354 891 -	80,3 118,1 297 -
1620.	□□□.□□.□	□□□.□□.□	156 × 196	50 4	50			
2020.	□□□.□□.□	□□□.□□.□	196 × 196	60 6	60			
2520.	□□□.□□.□	□□□.□□.□	246 × 196	75 8	75			
3020.	□□□.□□.□	□□□.□□.□	296 × 196	75 8	75			

Ejemplo de pedido:

Portamatrices de precisión = 201.50.

$a_2 \times b_2 = 296 \times 196$ = 3020.

$b_1 = 75$ mm = 075.

Tipo de muelle 241.15. = 15.

Parte sup. con placa = 1

Código = 201.50.3020.075.15.1

Los portamatrices de precisión 201.50. pueden suministrarse también en tamaños y ejecuciones especiales, según sus especificaciones.

FIBRO

201.50.

Portamatrices de precisión para útiles combinados progresivos

201.50.

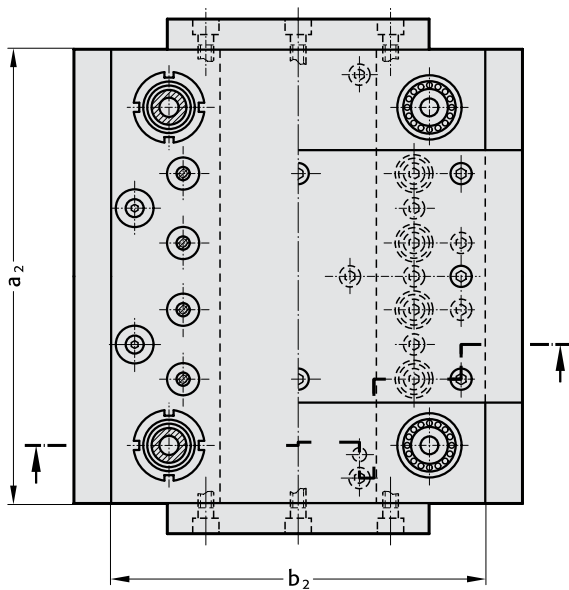
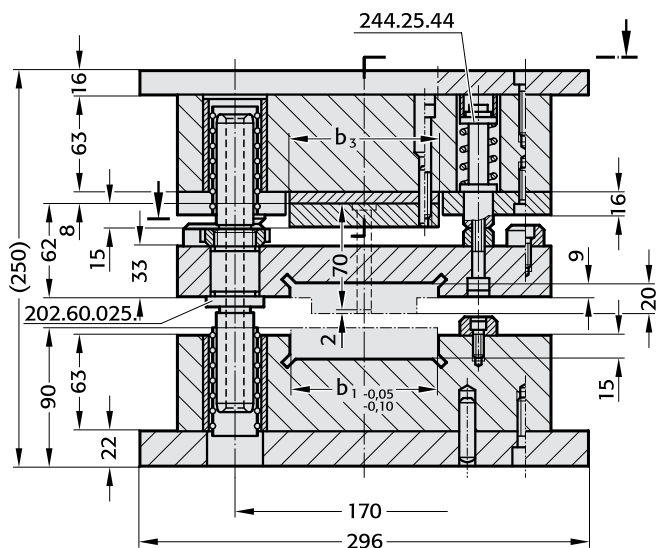

Ejecución

Posibilidad de fijación en la placa superior.

201.50.□□□□.□□□□.1

Con placa de fijación sobresaliente

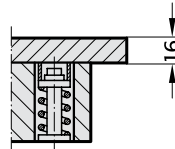

201.50.□□□□.□□□□.2

Con taladro roscado para tirante en la placa de fijación

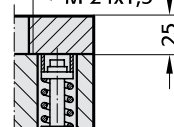

201.50.□□□□.□□□□.3

Con taladro roscado para tirante en la parte superior

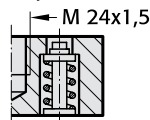

201.50.□□□□.□□□□.4

Con alojamiento de fijación en la parte superior

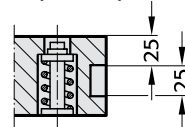

Modo de guiado

Guía a bolas

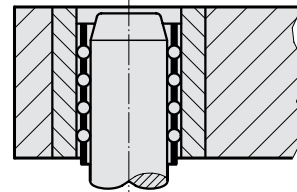

Anchura a rectificar b_1 a determinar por el cliente!

Sobre demanda, facilitaremos para la composición del útil datos 2D-CAD. El usuario ha de dibujar solamente las partes activas del útil.

Por modificación del grueso de la placa de sujeción puede reducirse en caso necesario la altura de la zona de alimentación de la chapa en hasta 16 mm, así como la altura de montaje del útil.

201.50.

Código mod.	Tipo de muelle Ejec.	Medida exter. $a_2 \times b_2$	Máx. compr. bin. de muelle b_1 max.	Máx. compr. bin. de muelle +dist. b_3	de muelle (sin pre-carga) 241...				Carrera con pre-carga	Pre-carga del muelle en N 241.□□.25.045			Fuerza R en N 241.□□.25.045					
					14	15	16	17		14	15	16	17	14	15	16	17	
201.50.1625.	□□□□.□□□□	156 × 246	60	4	60	8,0	8,0	7,8	5,4	4	212	323	748	977	53	80,8	187	244,2
2025.	□□□□.□□□□	196 × 246	75	6	75													
2525.	□□□□.□□□□	246 × 246	90	8	90													
3025.	□□□□.□□□□	296 × 246	100	8	100													
3525.	□□□□.□□□□	346 × 246	100	10	100													

Ejemplo de pedido:

Portamatrices de precisión = 201.50.

$a_2 \times b_2 = 296 \times 246$ = 3025.

$b_1 = 100$ mm = 100.

Tipo de muelle 241.15. = 15.

Parte sup. con placa = 1

Código = 201.50.3025.100.15.1

Los portamatrices de precisión 201.50. se pueden suministrar también en tamaños y ejecuciones especiales, según sus especificaciones.

Portamatrices de precisión para útiles combinados progresivos

201.50.

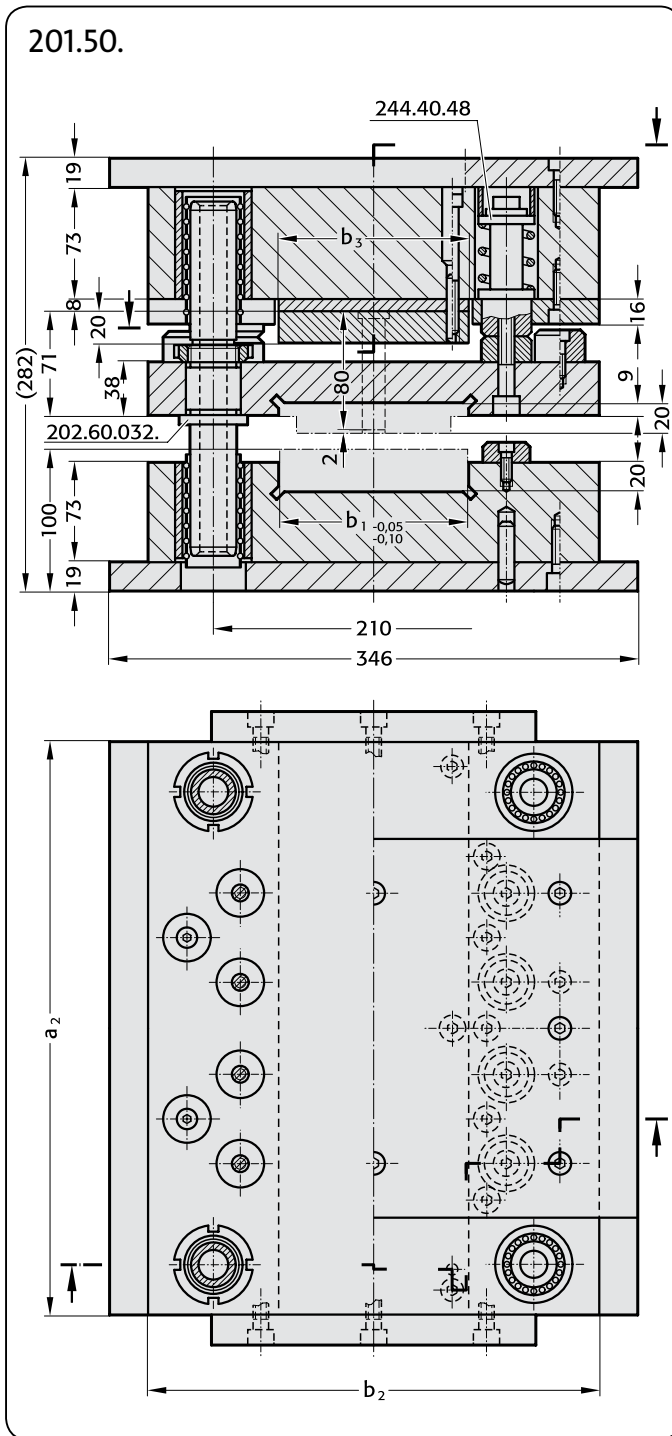

Ejecución

Posibilidad de fijación en la placa superior.

201.50.□□□□□.1

Con placa de fijación sobresaliente

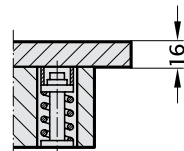

201.50.□□□□□.2

Con taladro roscado para tirante en la placa de fijación

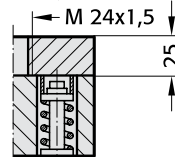

201.50.□□□□□.3

Con taladro roscado para tirante en la parte superior

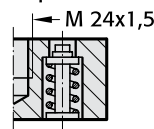

201.50.□□□□□.4

Con alojamiento de fijación en la parte superior

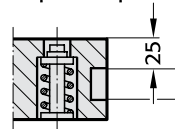

Modo de guiado

Guía a bolas

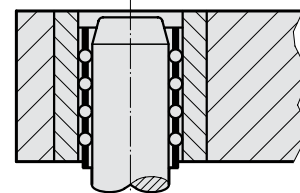

Anchura a rectificar b_1 a determinar por el cliente!

Sobre demanda, facilitaremos para la composición del útil datos 2D-CAD. El usuario ha de dibujar solamente las partes activas del útil.

Por modificación del grueso de la placa de sujeción puede reducirse en caso necesario la altura de la zona de alimentación de la chapa en hasta 16 mm, así como la altura de montaje del útil.

201.50.

Código mod.	Tamaño b_1	Tipo Ejec.	Medida exter. $a_2 \times b_2$	b_1 max.	Combin. de muelle +dist.	Máx. compr. de muelle (sin pre-carga) 241...	Carrera con pre-carga				Pre-carga del muelle en N				Fuerza R en N				
							14	15	16	17	241.□□.25.045	17	241.□□.25.045	14	15	16	17		
2030. □□□□□□□	196	75	196 x 296	75	4	75	7,0	7,0	5,0	4,2	8	736	1432	2800	5027	92	179	350	628,4
2530. □□□□□□□	246	100	246 x 296	100	6	100													
3030. □□□□□□□	296	100	296 x 296	100	8	100													
3530. □□□□□□□	346	125	346 x 296	125	8	125													
4030. □□□□□□□	396	125	396 x 296	125	8	125													

Ejemplo de pedido:

Portamatrices de precisión = 201.50.

$a_2 \times b_2 = 296 \times 296$ = 3030.

$b_1 = 100$ mm = 100.

Tipo de muelle 241.15. = 15.

Parte sup. con placa = 1

Código = 201.50.3030.100.15.1

Los portamatrices de precisión 201.50. se pueden suministrar también en tamaños y ejecuciones especiales, según sus especificaciones.

Columnas de guía intercambiables, fijación con valona central

La precisión del útil empieza por sus guías. Por este motivo, en la concepción de estos nuevos sistemas de fabricación hemos dado gran valor a la estabilidad y consecuentemente a la capacidad de carga de las columnas de guía. Con el montaje de columnas con valona central se obtiene una capacidad de carga de cada una de las columnas ocho veces superior.

Es sabido que en un guiado a bolas o rodillos la capacidad de carga lateral es inferior a la de guías lisas. Por este motivo, hasta ahora no era adecuado su empleo. Pero actualmente, con estas columnas, el guiado a bolas y rodillos se emplea en prensas rápidas.

Consecuencias de aplicación

Aplicando las columnas de guía con valona central, que sirve para bloquear la placa intermedia guía-punzones, la experiencia nos ha demostrado que se obtiene un alto grado de estabilidad, precisión y una cadencia superior.

Velocidad (ciclos/min.)

La parte móvil del útil, montado con columnas de guía macizas, produce en ciclos superiores a 500 por minuto – por leyes dinámicas – unas inercias demasiado altas. Para aminorar estas fuerzas, se emplean columnas huecas sujetas a la placa guía-punzones.

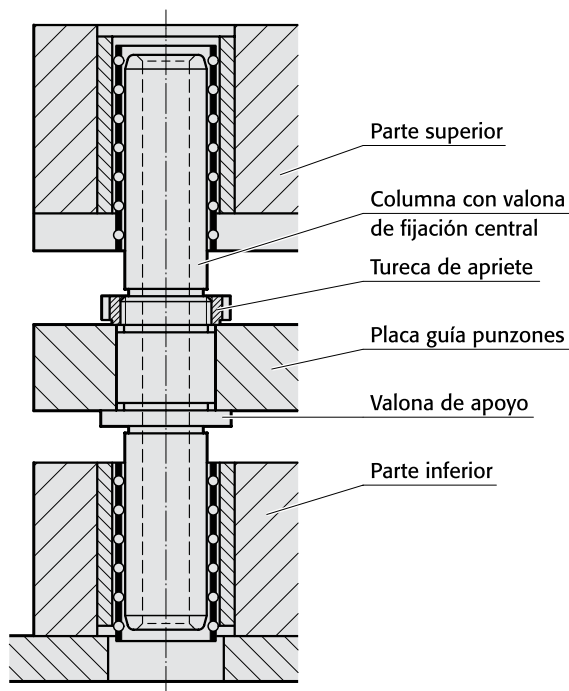

Combinación de muelles y distanciadores con la placa intermedia guía-punzones

La placa guía-punzones está dotada de unidades de muelle precargadas y distanciadores, instalados en forma compacta.

Las ventajas de estos elementos en sus ejecuciones 1 a 4 son las siguientes:

- a) Ahorro de espacio, ya que amortiguación y distanciamiento forman una sola unidad.
- b) Facilidad de cambio y adaptabilidad cuando es preciso reafilarse los punzones; no hay que desmontar su placa-guía.
- c) Las ejecuciones 1 y 2 permiten cambiar completamente el elemento muelle/distanciador, desmontando solamente la placa de fijación.

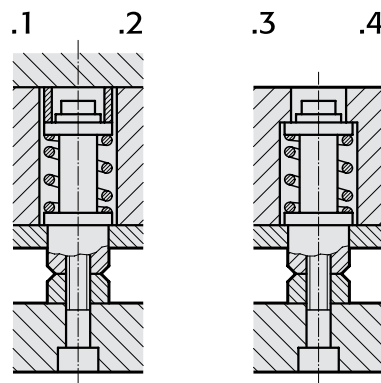

Placas de guía-punzones y matriz

Los orificios de la placa de las matrices y los de la placa guía-punzones, en su posición final, deben ser coincidentes; posibles desalineaciones pueden fluctuar solamente en micras.

Por experiencia, les encarecemos que pongan la máxima atención en que la exactitud de posicionado definitivo de los orificios entre sí sólo puede efectuarse después de todas las demás operaciones de mecanizado. Por este motivo suministramos los útiles solamente con orificios pre-rectificados, y que el cliente debe hacer la última operación de acabado.

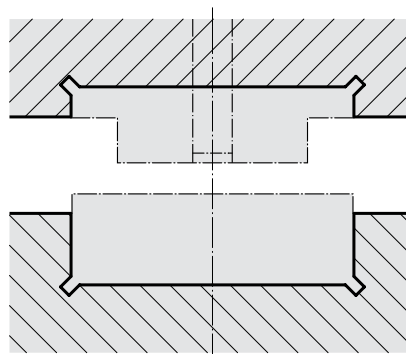



Portamatrices de cambio rápido

Descripción del sistema

La concepción del sistema de cambio de portamatrices con posicionado y sujeción mecánicos rápidos es una respuesta a la necesidad de

- Reducción del coste de las matrices
- Reducción del coste de preparación
- Posibilidad de reaccionar con rapidez para atender al mercado en caso de series cortas

En lugar de emplear muchos elementos completos individuales, el sistema de portamatrices de cambio rápido consiste en un armazón básico, el cual permanece en la máquina como utillaje madre, donde los útiles intercambiables se introducen sin guía-útiles especial.

Los útiles, pre-montados sobre una placa de montaje, se introducen en el armazón de cambio rápido hasta el tope. Girando las cuatro palancas frontales, los pasadores de posicionado son introducidos en sus alojamientos en la placa de montaje.

A continuación, se giran los cuatro tornillos prisioneros frontales hexagonales mediante una llave de tubo, los cuales, a través un plano inclinado, producen el bloqueo automático del elemento de sujeción.

Ejecución

Los útiles intercambiables para introducir en el portamatrices pueden emplearse como

- Matrices progresivas
- Útiles de corte
- Útiles de embutición
- Útiles de plegado
- Útiles combinados etc.

Ayudas para la preparación y el ensayo

Los útiles intercambiables para introducir en el portamatrices, por regla general y por motivos de coste, no se equipan con un guiado propio. Para facilitar la alineación de las partes inferior y superior del útil, éstas pueden ser provistas de unidades de centrado cónicas.

Como ayuda adicional para la preparación y pruebas de los útiles intercambiables fuera del portamatrices de cambio rápido, ofrecemos la prensa de preparación y ensayo 201.98.

Preparación

Las operaciones de

- Introducción
- Posicionado
- Sujeción

pueden realizarse en sólo 1 minuto.

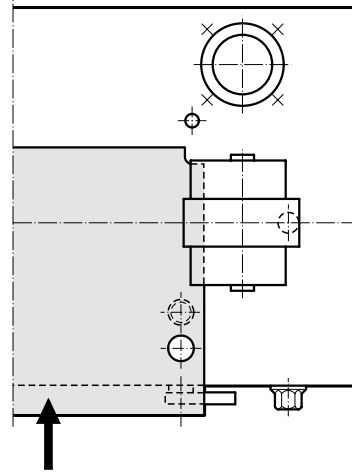
Introducción**Espesores de chapa**

Para chapas con espesores inferiores a 0,4 mm, el empleo de portamatrices de cambio de útiles no es siempre aconsejable, debido a la pequeña franquicia de corte.

La precisión de repetibilidad y posicionado de los útiles intercambiables introducidos es inferior a 0,02 mm.

La alineación de las partes superior e inferior del útil a introducir puede ser mejorada mediante el empleo unidades de centrado cónicas hasta una precisión que permite trabajar igualmente chapas con espesores inferiores a 0,4 mm.

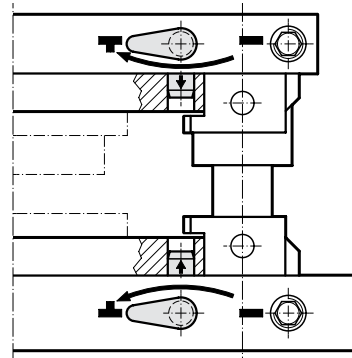
Posicionado**Ayuda para el centrado**

Los útiles intercambiables para introducir en el portamatrices pueden ser equipados con unidades cónicas de centrado.

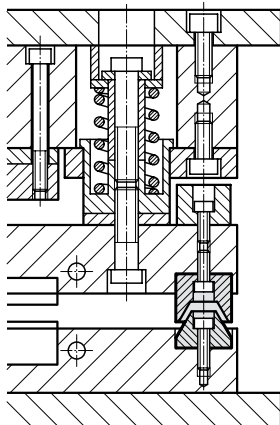
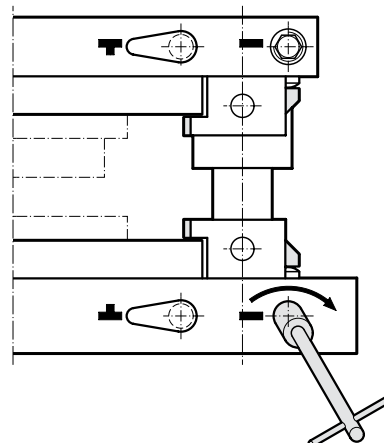
**Sujeción**

Sistema de cambio rápido de matrices

201.95.

Parte superior del portamatrices de cambio

- 1 Placa superior
- 2 Placa de montaje intercambiable
- 3 Casquillo-guía de columna, a elegir de acero sinterizado o a bolas
- 4 Elemento de sujeción
- 5 Pasador de posicionado retráctil
- 6 Palanca de posicionado
- 7 Tope
- 8 Tornillo prisionero

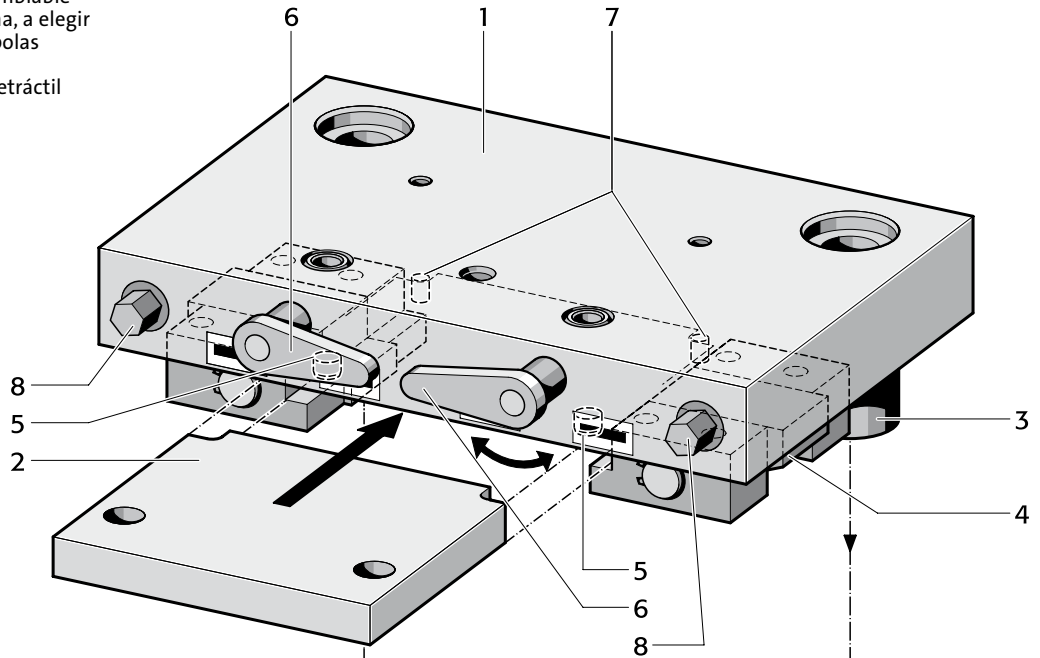

Parte inferior del portamatrices de cambio

- 1 Placa inferior
- 2 Placa de montaje intercambiable
- 3 Columna de guía
- 4 Elemento de sujeción
- 5 Pasador de posicionado retráctil
- 6 Palanca de posicionado
- 7 Tope
- 8 Tornillo prisionero
- 9 Placa postiza
- 10 Llave de tubo

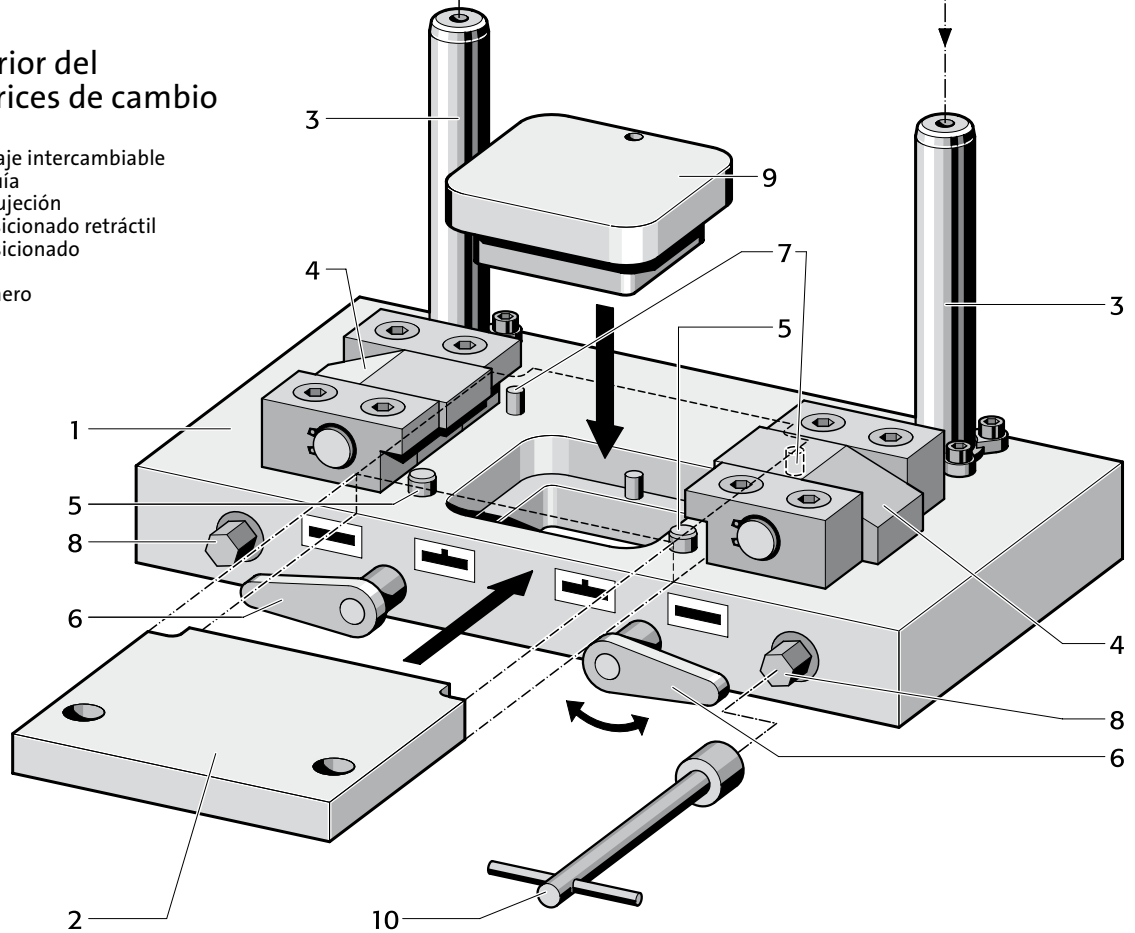

FIBRO

201.95.

Portamatrices de cambio rápido

201.95.

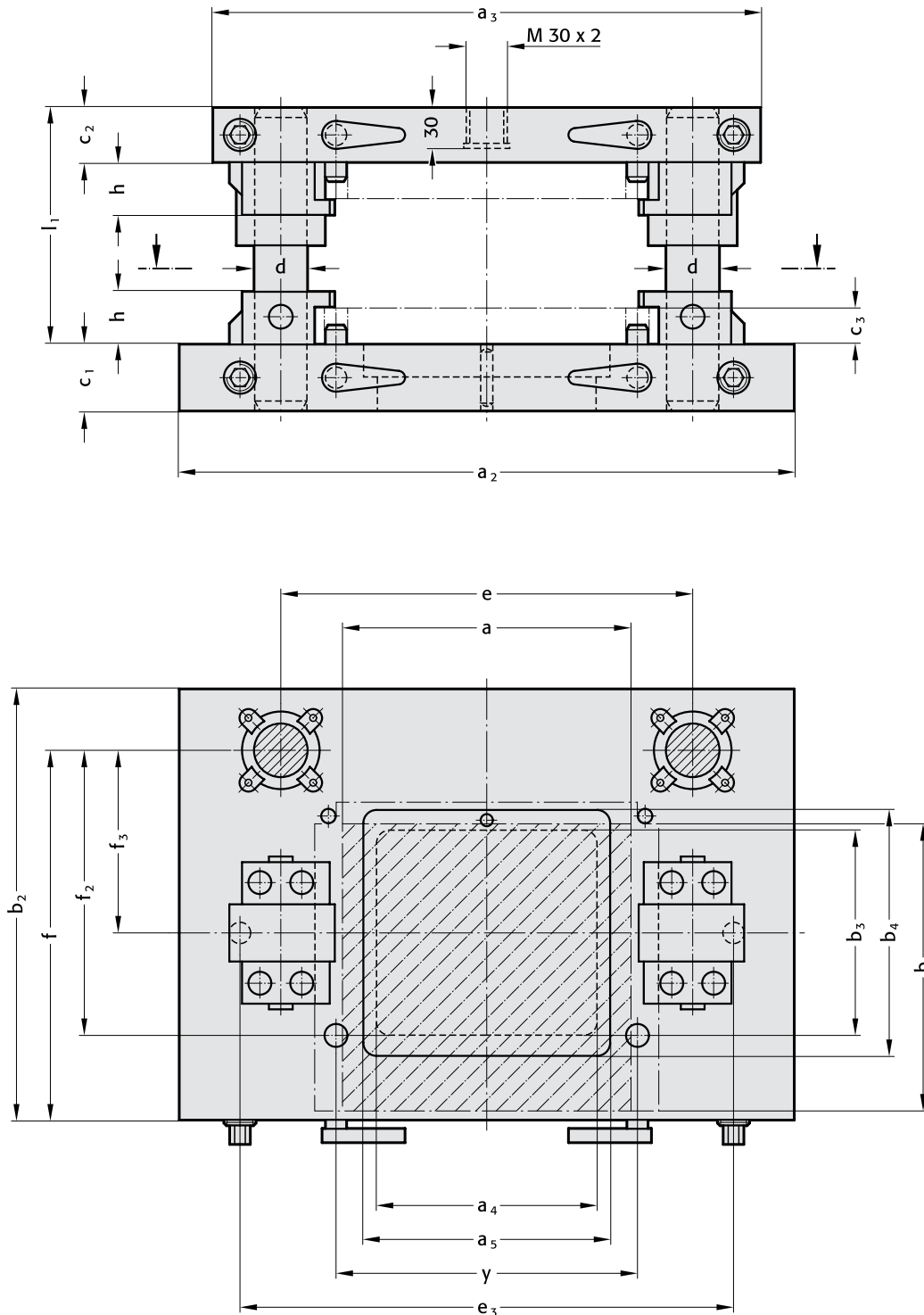

201.95.

Superficie de trabajo

Código	a x b	a_2	a_3	a_4	a_5	b_2	b_3	b_4	c_1	c_2	c_3	d	e	y	e_3	f	f_2	f_3	h	l
201.95.1010.	100 × 100	350	300	80,5	-	200	60	80,5	40	40	16	25	220	120	260	168	113	93	29	160
201.95.2121.	210 × 210	450	400	161	180,2	315	150	180,2	50	40	25	40	300	220	360	270	208	133	38	180
201.95.3030.	300 × 300	550	500	241	270,5	420	220	250,5	63	40	25	40	380	320	460	365	305	185	38	180
201.95.3521.	350 × 210	600	550	320	-	315	120	150	50	40	25	40	450	370	510	270	208	133	38	180

Para completar el Código con el tipo de guía: .831 (lisa), .862 (a bolas)

Placas de montaje Placas postizas

Placa de montaje

Cada útil intercambiable (parte inferior y superior) se atornilla y enclavija a una placa de montaje.
La placa de montaje formará parte del útil intercambiable correspondiente.

201.96.

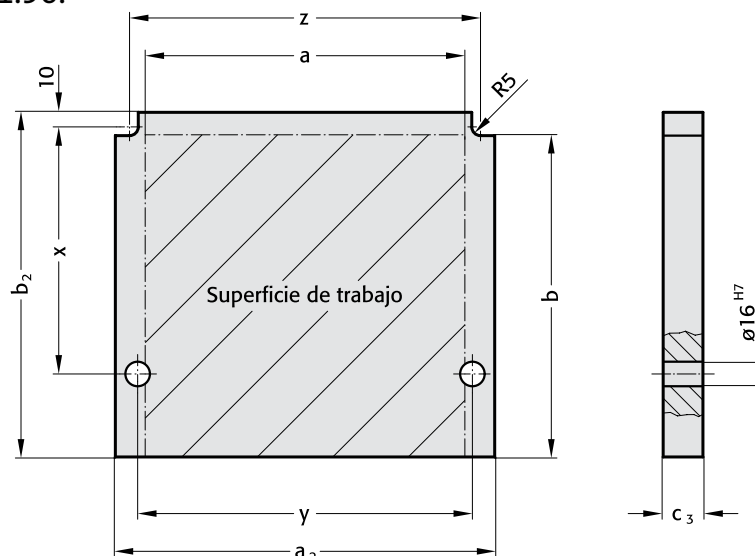

201.96.

Código	Superficie de trabajo a x b	a ₂	b ₂	c ₃	x	y	z
201.96.1010	100 x 100	150	115	16	50,1	120	130
201.96.2121	210 x 210	250	225	25	160,1	220	230
201.96.3030	300 x 300	350	315	25	250,1	320	330
201.96.3521	350 x 210	400	225	25	160,1	370	380

Placa postiza

Es necesario cambiar esta placa según aplicaciones:

- diferentes medidas de oberturas de expulsión para diversos útiles
- al emplear cojines con muelles, expulsores así como otras condiciones constructivas.

Se asegura el posicionado de la placa por medio de un orificio/pasador antigiro.

201.97.

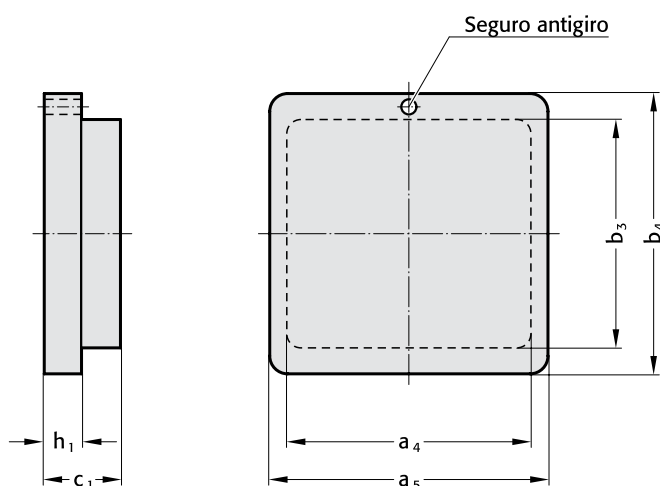

201.97

Código	Superficie de trabajo a x b	a ₄	a ₅	b ₃	b ₄	c ₁	h ₁
201.97.1010	100 x 100	80	-	60	80	40	20
201.97.2121	210 x 210	160	180	150	180	50	25
201.97.3030	300 x 300	240	270	220	250	63	30
201.97.3521	350 x 210	320	-	120	150	50	25

FIBRO

201.98.

Prensa de preparación y ensayo

201.98.

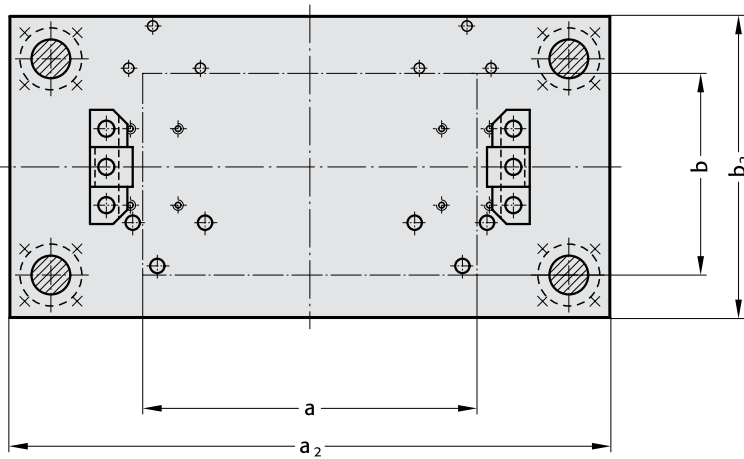
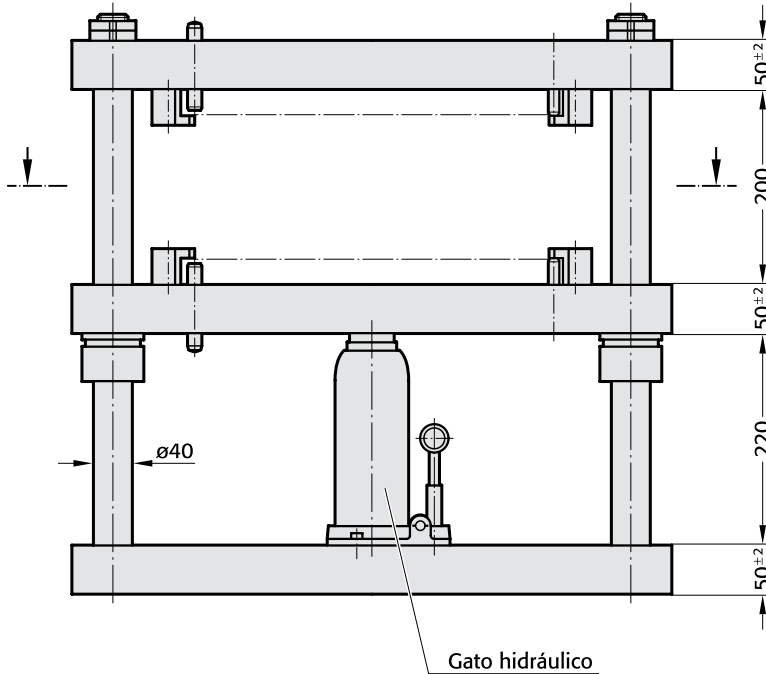

Descripción:

La prensa de preparación y ensayo de funcionamiento manual sirve para el montaje preliminar y ensayo de útiles intercambiables en el portamatrices de cambio rápido.

Las funciones de posicionado y sujeción son las mismas en el portamatrices de cambio rápido, pero en ejecución simplificada.

Aparte de las funciones descritas, sirve esta pequeña prensa de accionamiento manual al constructor de útiles como ayuda constante para clavar y extraer columnas y casquillos, así como para ajustar y ensayar los más variados útiles y herramientas.

Fuerza de prensado hasta 10 tm.

201.98.

Código	Superficie de trabajo		
	a x b	a ₂	b ₂
201.98.1010.863	100 x 100	315	250
3030.863	210 x 210	630	315
	300 x 300		
	350 x 210		

Material:

Placas: St 52-2

Ejecución:

Casquillos con valona
 Guía a bolas
 Gato hidráulico de 10 tm

